

# Foreword

## **Hello ,dear user:**

Thank you for your trust and love for our products! The agricultural mini excavator series produced by our company is a kind of agricultural mini excavator mainly focusing on excavation operations and supplemented by hoisting and unloading operations. Excavation and loading and unloading requirements under different operating conditions such as , hills, forest areas, etc., are also suitable for brick and tile factories, kilns, rivers, buildings, dredging, and road construction. It can reduce the physical labor of workers, speed up the construction progress, and improve the level of mechanization. It is the ideal main force for farmland operations and small projects.

In order to enable users to correctly grasp the knowledge of the use, adjustment, maintenance and repair of this machine, and give full play to the functions of the excavator, please read this operation and maintenance manual carefully and implement the provisions in this operation and maintenance manual. For the use and maintenance of the supporting engine, please refer to the "Engine Operation Manual" prepared by the supporting engine factory.

## **Operation part:**

The technical reference for the driver to use the machine, during which the driver is instructed to check, start, operate and stop the machine with the correct procedures by means of graphic and text comparison. The operating techniques outlined in the manual are the basis for the driver to obtain the machine and its functions knowledge, you can improve your skills and skills.

**Maintenance part:**

User's guide for the maintenance of the whole machine. The specific maintenance measures of the machine are described in detail in the "Excavator Maintenance Catalog". The user should maintain the maintenance items separately according to the different working hours of the machine according to the requirements in the "Excavator Maintenance Catalog".

In extremely harsh, dusty or wet working conditions, the lubrication times should be increased appropriately according to the operation of the machine.

In order to show some structural features of the machine more intuitively, some of the demonstration pictures in this manual are set as structural perspective views, so the appearance of the actual product will be different. If the actual mechanical structure and technical parameters of the excavator are changed due to technical improvement and are not shown in this manual, please consult our company for the latest product information of

the product.

Before using or maintaining the machine, the relevant information should be approved, and the company's technical service station can be contacted if necessary. When purchasing parts, please state the excavator's factory date and number.

In order to facilitate your use, the company has established a complete "Three Guarantees Technical Service Outlets". If during the warranty period, the agricultural small excavator you purchased from our company has quality problems under correct use, please contact the excavator three-guarantee maintenance service station in this area in time.

Due to the continuous innovation of the company's product technology, we reserve the right to revise all interpretations of this manual.

If the actual product is different from the pictures in this manual, please refer to the actual product.

# Content

<b>Chapter 1 Safety Precautions and Safety Signs</b> .....	<b>5</b>
1.1 Safety Precautions .....	<b>5</b>
1.2 Safety signs .....	<b>15</b>
<b>Chapter 2 Pre-job Inspection (Required)</b> .....	<b>21</b>
<b>Chapter 3 Operation Instructions</b> .....	<b>31</b>
<b>Chapter 4 Precautions when doing homework</b> .....	<b>34</b>
<b>Chapter 5 Prohibited Behaviour in Homework (Required)</b> .....	<b>55</b>
<b>Chapter 6 Hydraulic Breakers</b> .....	<b>68</b>
<b>Chapter 7 Shutdown and Transportation Precautions</b> ...	<b>78</b>
<b>Chapter 8 Basic Parameters of Excavators</b> .....	<b>82</b>
<b>Chapter 9 Common Faults and Solutions</b> .....	<b>87</b>
9.1 Relief valve (safety valve) cleaning and system pressure adjustment.....	<b>89</b>
9.2 How to replace the ball shaft and seat of the multi-way valve.....	<b>91</b>
9.3 How to deal with multi-way valve spool spring falling off or spring tightening screw loose.....	<b>93</b>
9.4 Drop off track installation.....	<b>94</b>
9.5 Engine won't catch fire when running out of gas.....	<b>96</b>
9.6 Replace the fuse (wire).....	<b>98</b>
<b>Chapter 10 Maintenance and Care (Must Read)</b> .....	<b>100</b>

<b>10.1 Maintenance Considerations</b>	<b>100</b>
<b>10.2 Lubrication part diagram</b>	<b>119</b>
<b>10.3 Maintenance catalog</b>	<b>122</b>
<b>10.4 List of filter element models</b>	<b>123</b>
<b>10.5 Oil replacement method</b>	<b>124</b>
<b>10.6 How to replace the filter element</b>	<b>126</b>

# **Chapter 1 Safety Precautions and Safety Signs**

## **1.1 Safety Precautions**

### General Notes

It is your responsibility to follow relevant departmental safety regulations and laws, and to operate, inspect and maintain the machine in accordance with the manufacturer's instructions.

In fact, all accidents are caused by failure to observe basic safety regulations and precautions.

Most accidents can be avoided by identifying potentially hazardous situations in advance.

Please read and understand all safety information that describes how to prevent accidents. Do not operate the

machine until you are confident that you understand how to properly operate, inspect and maintain the machine.

### **Follow all safety regulations**

The machine must be operated, inspected and maintained by trained and qualified personnel.

All rules, regulations, precautions and safety measures must be understood and followed during machine operation, inspection and maintenance.

Do not operate, inspect and maintain the machine under the adverse effects of alcohol, drugs, drugs, fatigue, or lack of sleep.

### **When an abnormality is found in the machine**

In the operation, inspection and maintenance of the machine, if any abnormality of the machine (noise, vibration, odor, oil leakage, false alarm, etc.) is found, the sales or service agent should be notified immediately and appropriate measures should be taken. Do not operate the machine until the abnormality is eliminated.

### **Operating temperature range**

To maintain machine performance and avoid premature wear, please observe the following operating conditions.

Do not operate the machine if the outdoor temperature exceeds +45° C or is lower than -15° C.

If the outdoor temperature exceeds +45° C, the engine may overheat, resulting in reduced engine oil performance. Also, hydraulic fluid can become very hot and cause damage to hydraulic equipment.

If operating at outdoor temperatures below -15° C, rubber parts such as gaskets may harden, causing premature wear or damage to the machine.

Consult your sales or service agent if it is necessary to operate the machine outside the above outdoor temperature ranges.

### **Wear suitable clothing and protective equipment**

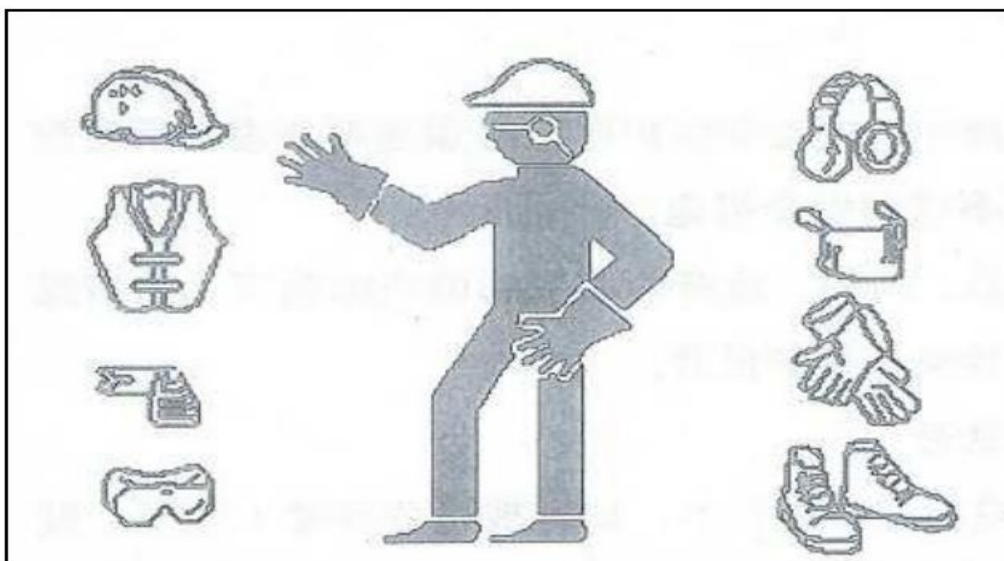

Do not wear loose clothing or accessories that could catch levers or moving parts.

Do not wear oily or fuel-stained clothing that can catch fire.

Wear safety shoes, safety helmets, safety glasses, filter masks, thick gloves, ear protection and other protective equipment according to the requirements of the working environment.

Use hearing protection when operating the machine. Prolonged exposure to loud noise can damage or even completely lose hearing.

**Install a fire extinguisher and first aid kit**

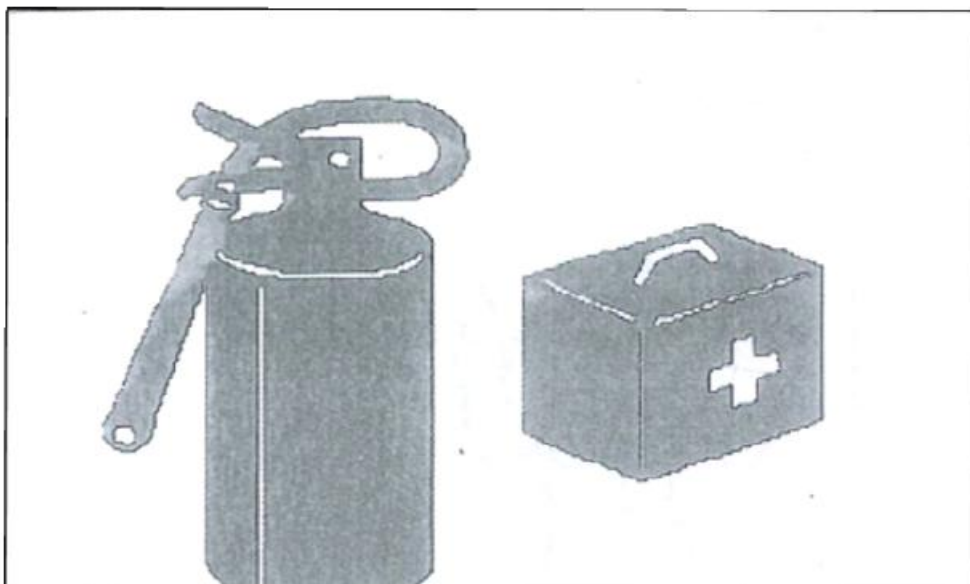

Be prepared for fires and accidents.

Learn how to use a safety fire extinguisher and first aid kit.

Learn how to put out fires and deal with accidents.

Know how to contact emergency assistance and make an emergency contact list.

**DO NOT REMOVE SAFETY DEVICES**

Make sure that all guardrails etc. are in place and secure. Repair or replace damaged parts before operating the machine.

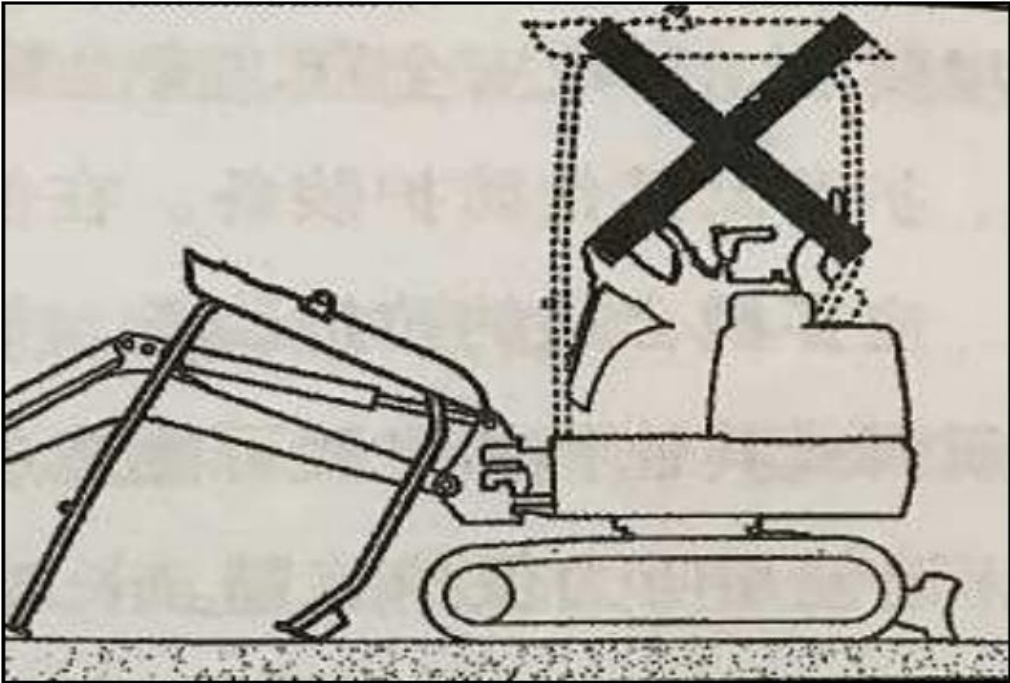

Do not remove any safety devices except for inspection. Keep all safety devices in good working condition at all times.

Equipped with signalmen and flag bearers

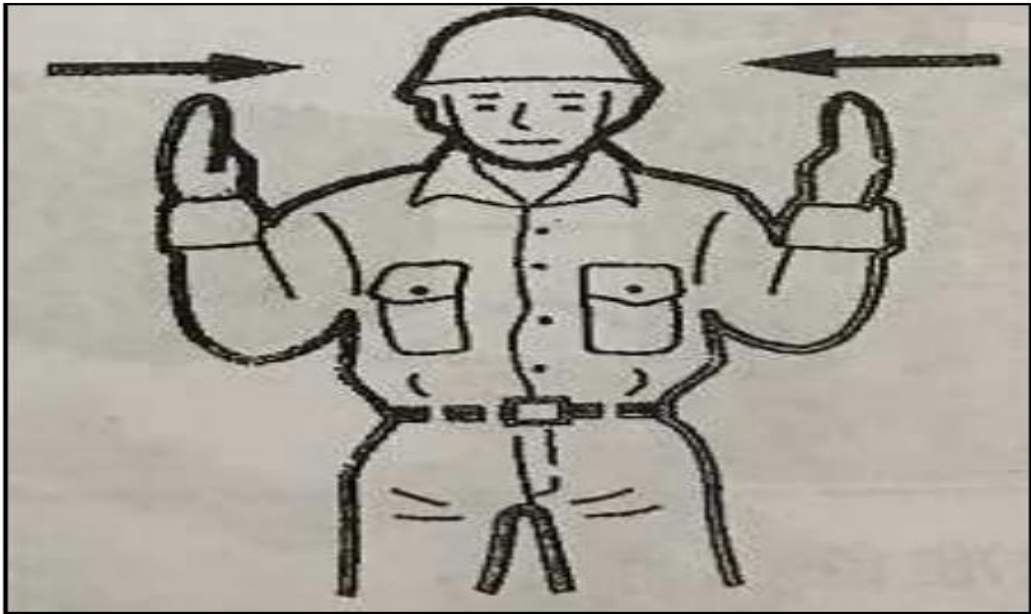

Learn how to use the gestures required for specific assignments and identify who is responsible for gesturing.

All personnel must fully understand all gestures.

Operators must only respond to designated personnel's gestures, but must obey anyone's stop gesture at all times.

The signaller must stand clearly visible when giving a signal.

### **Precautions when getting up or getting out of the driver's seat**

When standing up from the cab, lower the work equipment to the ground and stop the engine. Accidentally touching any of the control handles can move the machine and cause serious injury or death.

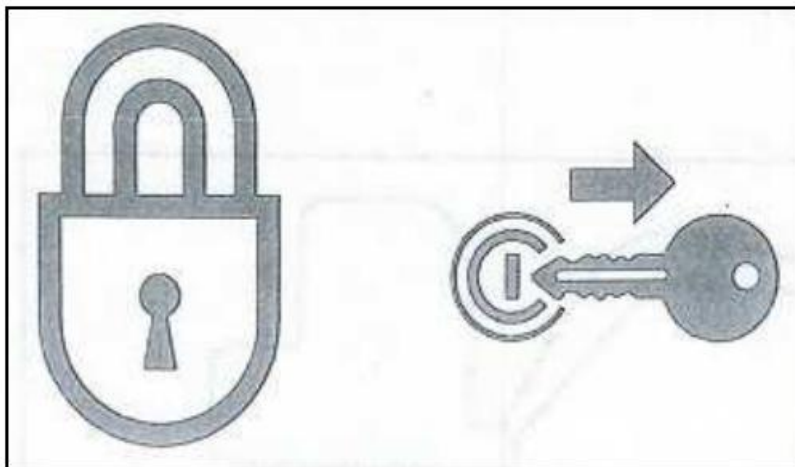

PLEASE NOTE: Dozer, Boom and Auxiliary Hydraulic Controls, Do Not Touch These Controls. Before leaving the cab seat, the work equipment should be lowered to the ground

and the engine should be turned off. At the same time, turn off the headlights, key switch and main power switch.

### Avoid fire and explosion hazards

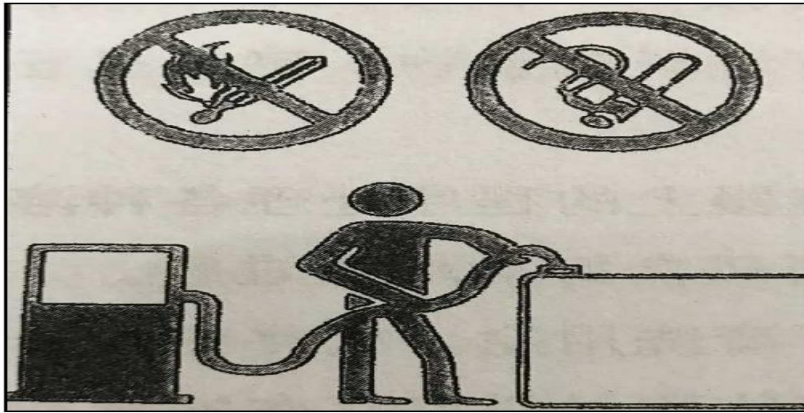

Keep fuel, lubricating oil, grease and antifreeze principles to avoid flames. Fuel is particularly flammable and very dangerous.

When handling these combustibles, keep away from lighted cigarettes, matches, lighters, and other sources of flame or ignition.

Do not smoke or open flames while handling fuel or working on the fuel system.

Do not leave the job site when refueling or lubricating oil.

Do not remove the fuel cap or add oil while the engine is running or has not cooled down. Also, do not splash fuel on hot surfaces of the machine or electronic system components.

Clean up spilled fuel or lubricant immediately.

Check for fuel and lubricant leaks. Please exclude leaks and clean machine before operation.

Move flammable items to a safe place when polishing or welding.

Do not cut or weld on pipes or tubes that contain flammable liquids. Wash thoroughly with non-flammable solvent before cutting or welding.

Remove any trash or debris from the machine. Make sure that no oily rags or other flammable objects remain on the machine.

Dispose of various solvents or dry chemicals (foam-type fire extinguishers) according to the manufacturer's procedures on the container. Do it in a well-ventilated place.

Never use fuel for cleaning purposes. Always use non-flammable solvents.

Keep all flammable liquids and materials in a safe and well-ventilated area.

A short circuit in the electronic system can cause a fire. Check daily for loose or damaged wire connections. Retighten loose connectors and wiring clips. Repair or replace damaged wires.

### **Fire caused by pipes**

Make sure hose and tube snaps, guards and bumpers are securely fastened. If loose, the hose or tube can be damaged by vibration or contact with other parts during operation. This may cause high pressure oil to spray out, resulting in fire or injury.

### **Engine exhaust is toxic**



Do not operate the engine in an enclosed location with poor ventilation.

If natural ventilation is not possible, ventilation fans, fans, extended exhaust pipes or other ventilation devices should be installed.

### **Handling asbestos dust**

Lung cancer may be caused by inhaling asbestos dust. When handling materials that may contain asbestos, take the following safety measures:

Never use compressed air for cleaning.

Avoid polishing or sanding parts that contain asbestos.

When cleaning, use a vacuum setting with a HEPA filter.

If no other means of controlling dust are available, wear prescribed respirator. When working indoors, install a ventilation system with a polymer filter.

Do not allow unauthorized personnel to enter the work area while working.

Strictly follow the rules and environmental standards applicable to the work area.

**Be careful not to crush**



Never place hands, feet or other body parts between the upper and lower frames or between the tracks, between the body and work equipment, or between the cylinder and moving parts. As the machine moves, these voids can change in size and can cause serious injury or death.

## **Use optional products**

Consult a review before installing options. Depending on the type of attachment or their combination, the attachment may come into contact with the cab or other parts of the machine. Before use, make sure that the installed options do not come into contact with other parts.

Do not use unapproved attachments. Doing so may compromise safety or adversely affect the operation or service life of the machine.

The company is not responsible for any injury, accident or product damage caused by the use of unlicensed accessories.

## **Do not modify the machine**

Unauthorized modifications to the machine can result in injury or death. Never make unauthorized modifications to any part of the machine.

## **1.2 Safety signs**

In order to ensure the safety of operators and staff around the work area, the following safety signs (marks) should be placed on certain parts of the machine. Walk around the machine with this manual to see what and where these safety signs are. Review these signs and operating instructions in this manual with your machine operator.

Safety signs should be kept clean, legible and legible. If any safety labels are detached or damaged and become illegible, replace them with new labels. Please provide your product serial number when ordering new labels from a company service representative.

When the part/body posted on the safety sign has been replaced, a new label should be posted on the new part/body.

### 1.2.1 Stay away from slew zone signs

△It is strictly forbidden to stand in the machine turning area.

△Do not damage or remove this marking from the machine.

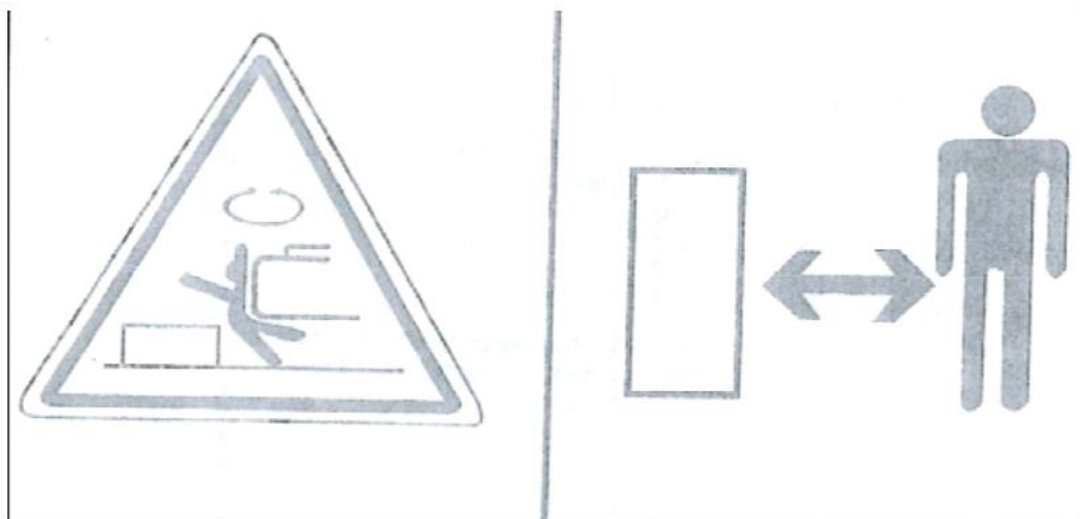

### 1.2.2 Fuel label

This logo is on the fuel tank

△Turn off the engine when refueling, and keep away from all open flames when refueling.



### 1.2.3 Fuel Precautions

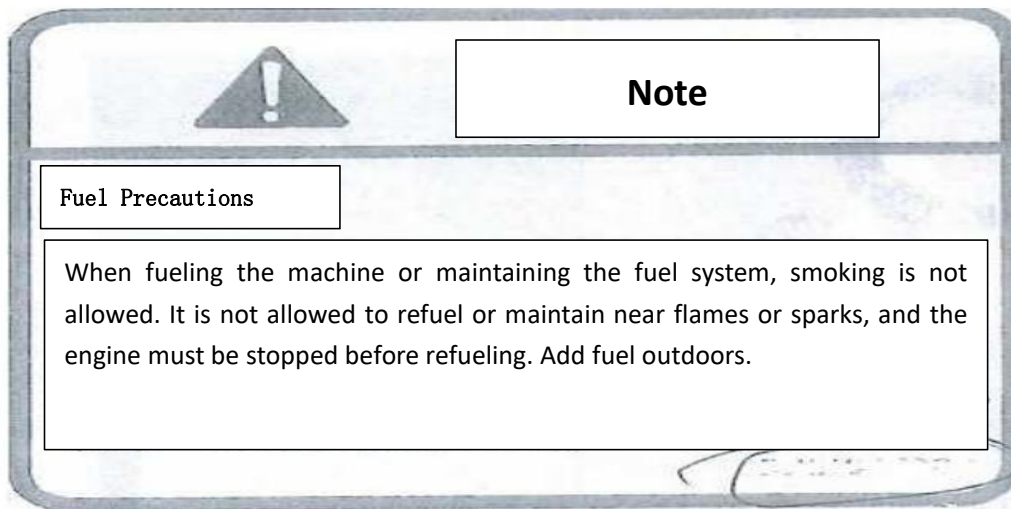

### 1.2.4 Battery usage precautions

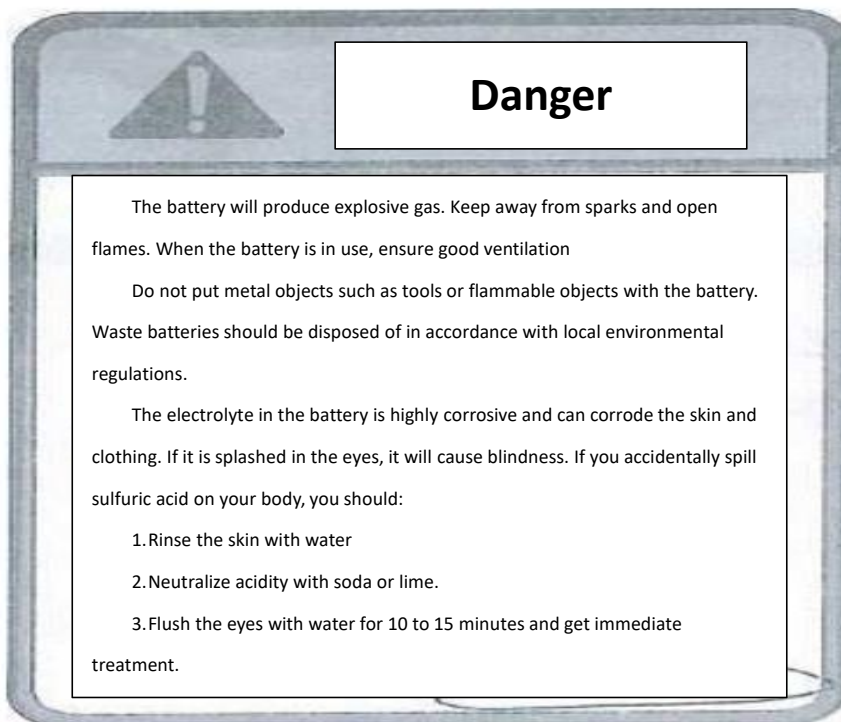

1.2.5 It is strictly forbidden to stand in the working area



1.2.6 Stay out of the excavation area

This logo is located on both sides of the stick



## 1.2.7 Precautions for Adjusting Track Tension

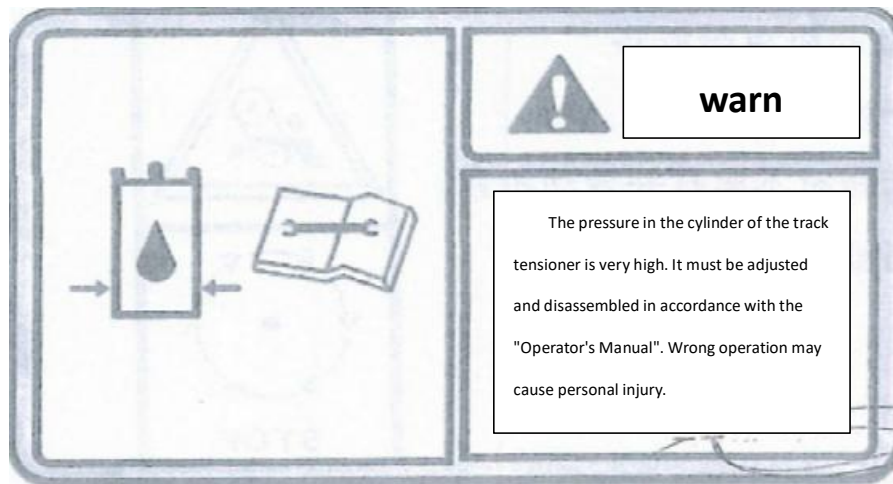

## 1.2.8 Reservoir and accumulator maintenance warning signs

This logo is located in the upper right corner of the rotary platform

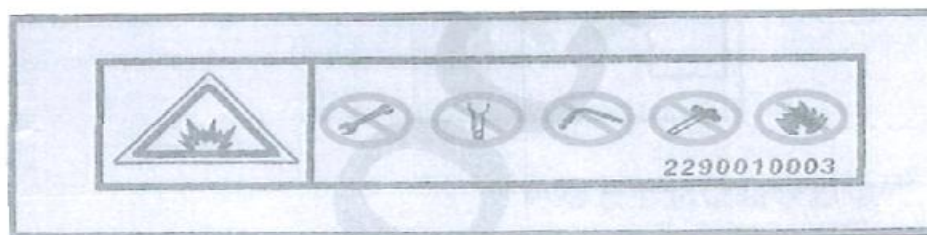

## 1.2.9 Keep away from engine belt markings

△Do not open the hood while the engine is running.

△Do not touch the exhaust pipe to prevent burns.

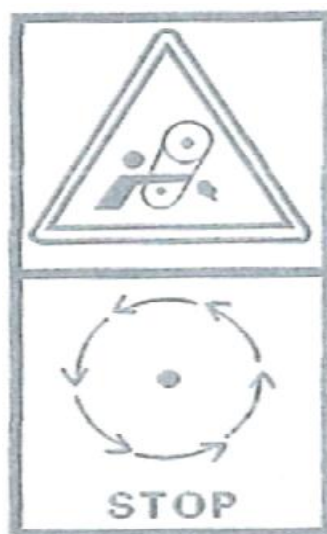

### 1.2.10 Hydraulic oil identification

This logo is located on the hydraulic oil tank



### 1.2.11 Precautions for getting on and off

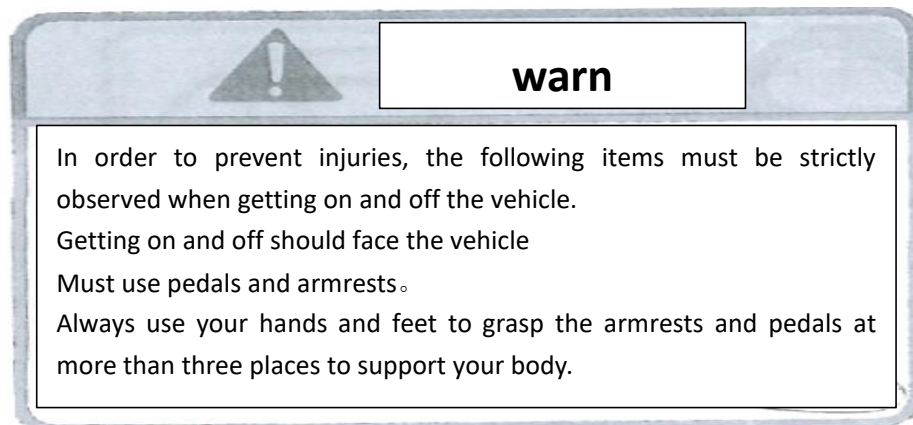

### 1.2.12 Anti-skid warning sign



# Chapter 2 Pre-job Inspection (Required)

Before the operation, you should fully understand the condition of the vehicle and the working area to ensure safety.

## **2.1 Fuel quantity check**

The fuel capacity of the vehicle should be checked before operation. When the fuel is insufficient, the fuel should be replenished in time to prevent the air from entering the pipeline due to the exhaustion of fuel, and the machine may fail to catch fire after refueling. See chapter 9.5 for details on how to deal with failure to catch fire.

Due to the large difference in climate in different areas where the machine is used, in areas with low temperature in winter, you must choose gasoline that is suitable for the local temperature. For example, the minimum temperature is -20 degrees. When adding gasoline, you need to use -30# gasoline, otherwise the gasoline will freeze and it will be difficult to start or Unable to start machine.

## **2.2 Track Tension Check**

The tension of the crawler should be checked before operation. If the crawler is too loose, use 24 wrench to

tighten the track (as shown in the figure below). The tightening form of different models is slightly different, but the position is generally the same, and the actual product shall prevail.

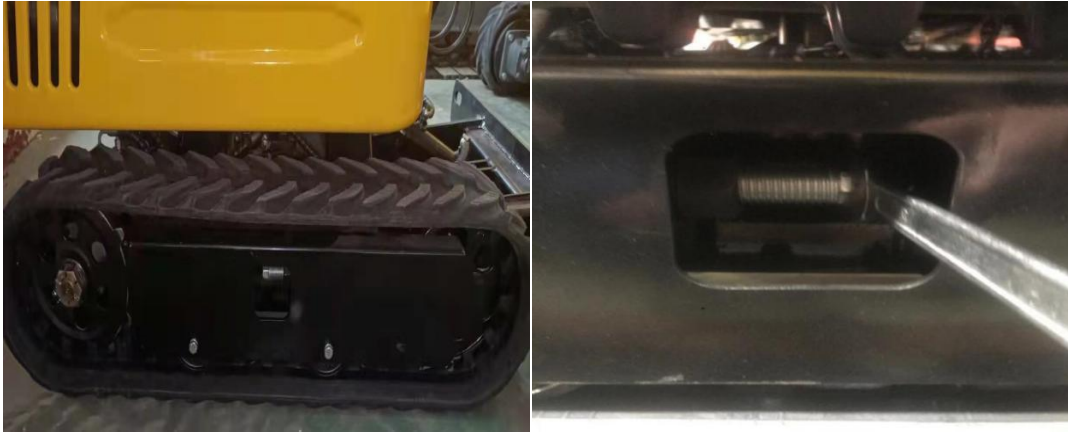

If the track is too loose, it is easy to fall off when turning, turning around, or walking on one side. Once the track falls off, it is more difficult to install.

### **2.3 Hydraulic oil quantity check**

Check the hydraulic oil level before operation. When the hydraulic oil level is too low, the body is tilted, and the hydraulic oil in the fuel tank is biased to one side, which will cause the oil pump to not absorb oil and the vehicle to do nothing (if this action occurs, the engine should be turned off immediately, and the oil pump cannot be pumped. Continuing to work when the oil arrives will cause the hydraulic pump to be seriously worn or even damaged) It is

necessary to add hydraulic oil or pad the body. If there is no hydraulic oil or the body cannot be lifted, try to hold the rotary valve stem for some models with mechanical operating systems , Push the boom hard, turn the boom to the side where the body is high, then start the machine, if there is any movement, firstly adjust the vehicle to the level, and then add hydraulic oil.

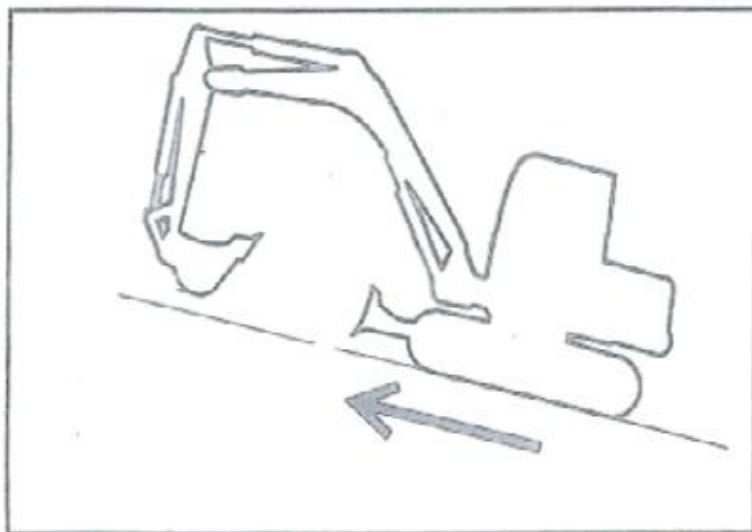

## **Oil inspection**

The hydraulic oil used by the excavator is 46# anti-wear hydraulic oil. Due to the large difference in climate in different regions, the viscosity of the hydraulic oil will be affected if the temperature is too low or too high, resulting in insufficient system pressure or abnormal noise, and even accelerated wear of the oil pump. . In special climate (too cold or too hot) areas, hydraulic oil suitable

for local temperature should be selected according to local climatic conditions.

### 2.4 oil quantity check

Before the operation, the engine oil should be checked to see if the oil is sufficient (due to the climbing, descending, tilting, and other conditions of the machine during operation, the oil amount should be close to the upper limit of the oil dipstick to prevent the oil pump from being unable to pump oil), When it is insufficient, it needs to be replenished in time. (The oil will work slowly with the engine, so it is necessary to check the oil level regularly.) Otherwise, it will lead to excessive wear of the engine or cylinder pulling, cylinder pulling or other problems caused by lack of oil. Engine manufacturers No warranty.

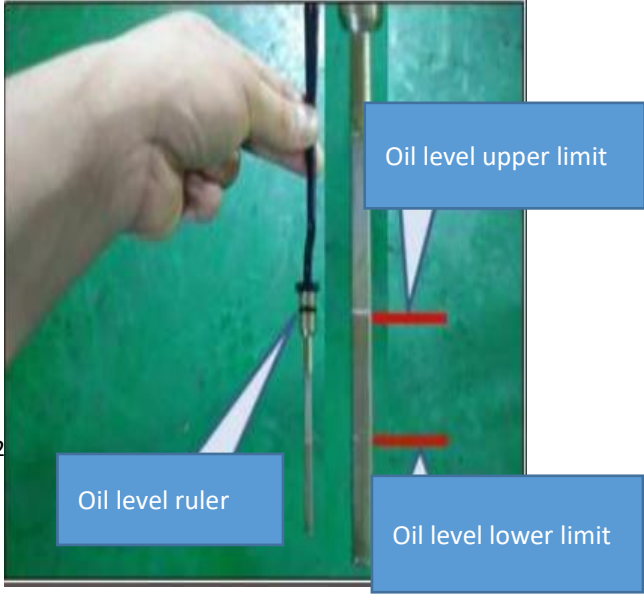
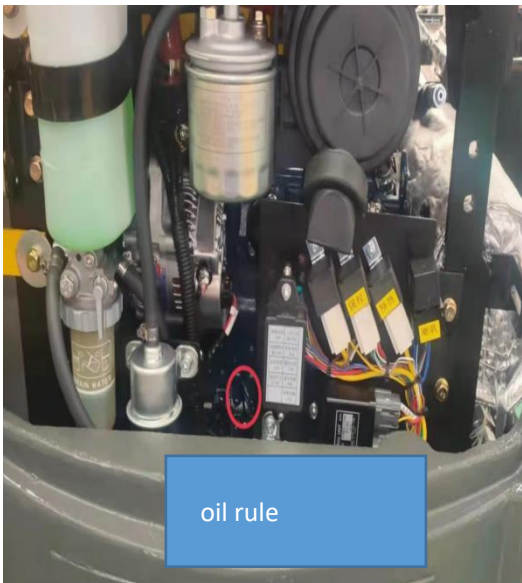
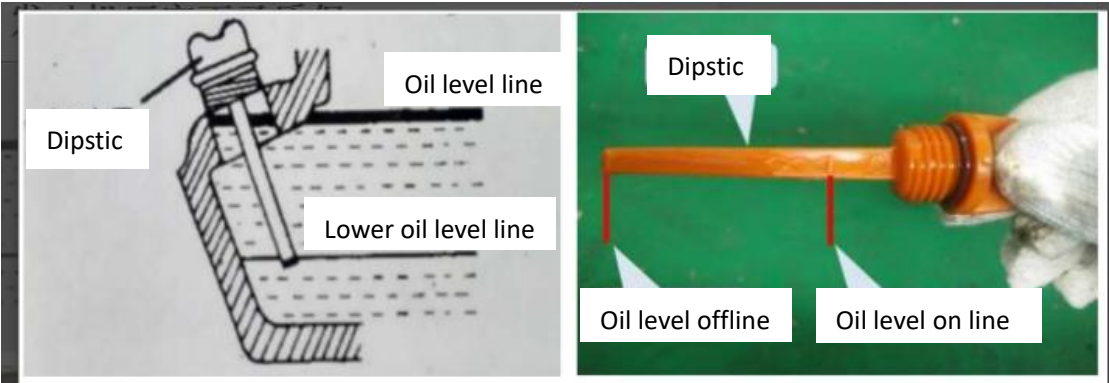

## **Check of antifreeze capacity**

The antifreeze should be checked before the operation, and the antifreeze will be gradually lost during the use of the excavator, so when the antifreeze is reduced, it needs to be supplemented in time (no water in the water tank, water will lead to the water tank scale, rust, corrosion, the resulting damage to the parts manufacturers will not be three guarantees). In addition, there is an expansion kettle next to the water tank, and between the cover of the water tank with a hose connection, in the process of machine work, the steam in the water tank will condense in the kettle, so the antifreeze in the kettle should be poured into the water tank in time. (Warm tips do not add antifreeze when the machine temperature is too high, to prevent scald!!!)

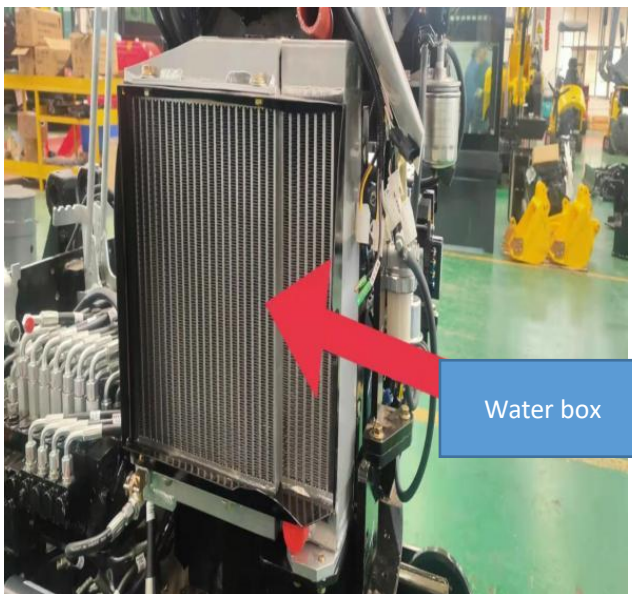
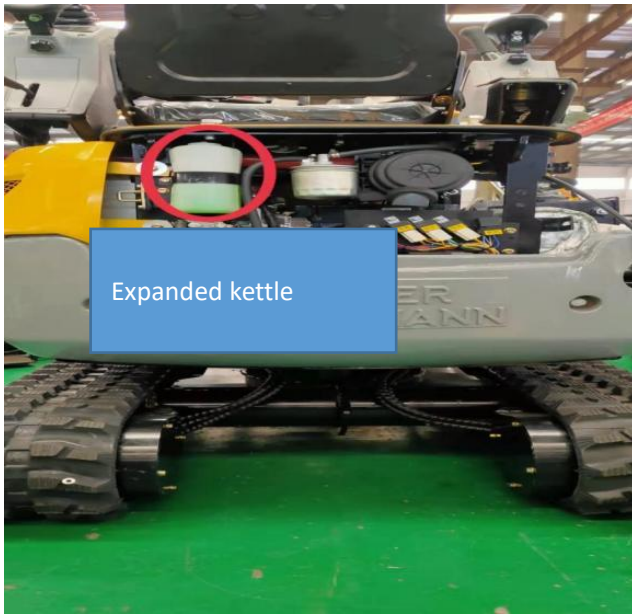

## 2.5 Lubrication point inspection

Each lubrication point of the excavator should be checked before operation. Generally, grease should be added to each lubrication point every 8 hours of operation (refer to Chapter 10-10.2 for the number of lubrication points and the location of refueling). The amount of refueling should be sufficient,

and the frequency of refueling should be increased when the working conditions are bad.

## **2.6 Check the tightness of the fixing bolts of important parts**

Important components include slewing rings, slewing motors and engines. Before operation, check whether the fixing bolts of these parts are loose. If there are loose bolts, they must be tightened immediately. If necessary, consult the manufacturer. If the loose bolts are not checked or tightened, it may cause serious problems such as interruption of the gears of the slewing bearing and the slewing motor, falling off of the engine, damage to the wind ring and water tank.

## **2.7 oil leak inspection**

Before the operation, you should observe around the car and check the chassis to check whether the excavator has oil leakage. If there is, it should be tightened or repaired in time.

## **2.8 Work area inspection**

Check the topography and ground conditions of the work area, check the building structure when

working indoors, and take safety measures if necessary.

Be sure to avoid hazards and obstacles such as ditches, underground pipelines, trees, cliffs, overhead power lines, or areas that are at risk of falling rocks or landslides.

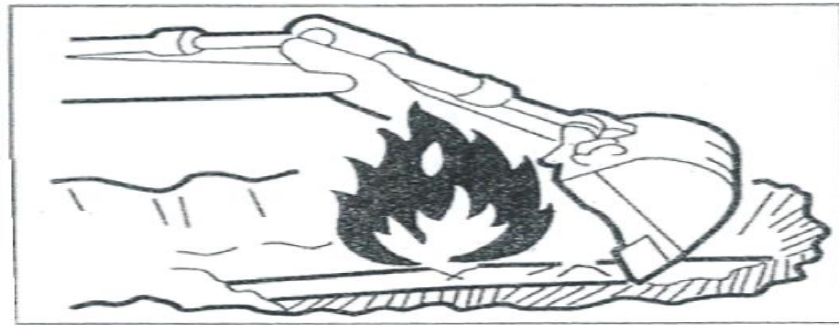

Check the location of buried gas pipes, water pipes and power cables with the administrator. If necessary, consult with the administrator and determine the specific security measures that must be taken to ensure security.

When working on the road, always consider the safety of pedestrians and vehicles, and use signalmen or signal instructions. The work area is isolated, and unauthorized personnel are not allowed to enter.

When working in water or crossing a shallow stream, the water depth, the firmness of the ground and the speed of the water flow should be checked beforehand.

## **2.9 Check the strength of the bridge**

When walking on bridges or structures, check the allowable load. If strength is insufficient, bridges or structures should be reinforced.

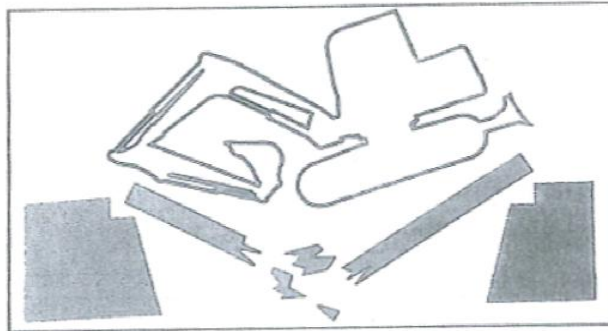

## **2.10 Always keep the machine clean**

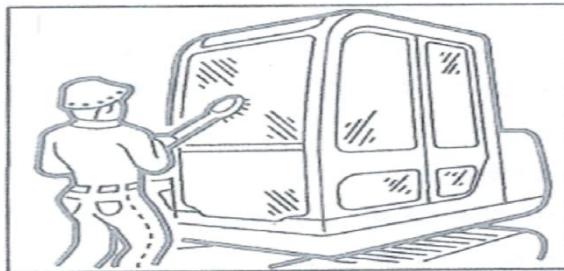

Wipe off oil, grease, mud, snow or ice to prevent accidents caused by slipping.

Remove all loose objects and unnecessary devices from the machine.

Remove dust, oil or grease from the engine area to prevent fire.

Clean around the operator's seat and remove any unnecessary objects from the machine.

## **2.11 Daily inspection and maintenance**

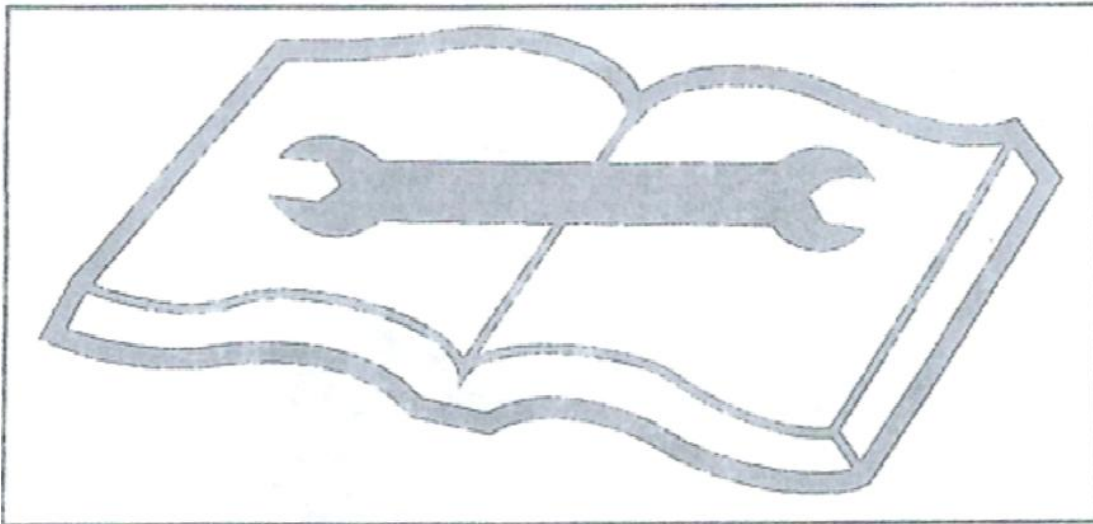

Failure to identify (or repair) machine abnormalities or damage can lead to accidents.

Carry out the specified inspections before operation and repair immediately if necessary.

In the event of an accident and inoperability or engine failure, immediately follow the shutdown procedure and park the machine securely until the failure is repaired.

## **2.12 Precautions in the cab**

Before entering the cab, remove mud and grease from the soles of the shoes. Operating the machine pedals with mud and grease on the soles of the shoes can cause accidents due to slippage underfoot.

Do not place parts or tools around the driver's seat.

Do not place any plastic bottles or install any suction cups in the cab. Plastic bottles or suction cups act as see-through and can cause a fire.

### **2.13 Safety measures before starting**

Support your body weight in a three-point safety stance when getting on/off the machine.

Do not jump on or off the machine. Do not attempt to get on or off a moving machine.

When getting in and out of the cab, first open the door fully to the locked position, and check that the door cannot move (for machines with a cab).



Climb up/down the footrests facing the machine and hold onto the handrails to support your body weight in a three-point safety stance (hands and feet). Never use the lever as a handle.

**2.14 Before starting the machine, please, any unauthorized persons leave the area**

Start the machine only after you are sure that it is safe to start by checking the following items.

1. Walk around the machine for a week to warn the maintenance personnel and those walking near it. Do not start the machine until you are sure that no one is around the machine.

2. Check the cab, control or starter switch for a "Do Not Operate" warning sign or similar sign. If so, do not start the engine or touch any levers.

## **2.15 Sit in the driver's seat and start the engine**

Adjust the seat to a firm lock.



fasten your seatbelt.

Check that the parking device is on and that all levers and pedals are in neutral.

Make sure no one is near the machine. Only start and operate the machine from the driver's seat.

Never attempt to start the engine by shorting the starter terminals.

## **2.16 Start with jumper cables**

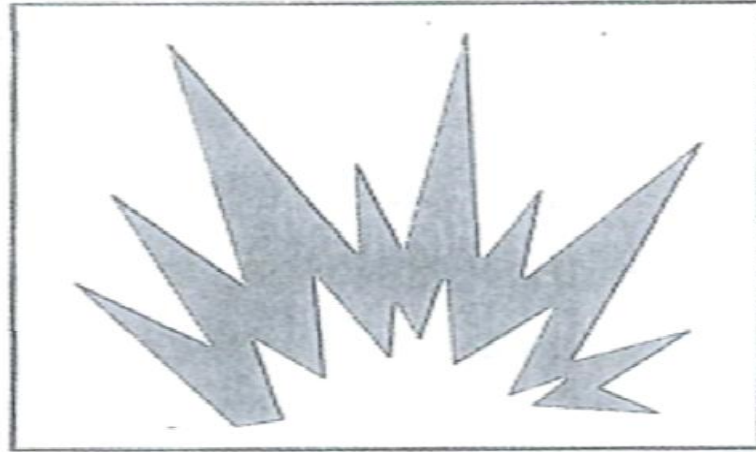

Starting with jumper cables should only be done as recommended. Improper use of jumper cables can cause battery explosion or unexpected machine action.

# **Chapter 3 Operation Instructions**

## **3.1 Working device operation instructions**

This sign is located on the front inside of the cab, check that the machine control mode is consistent with the sticker. If not, replace the decal to match the mechanical control mode before operating the machine.

△Failure to do so may result in personal injury or death.

L330 Schematic diagram of series operation:

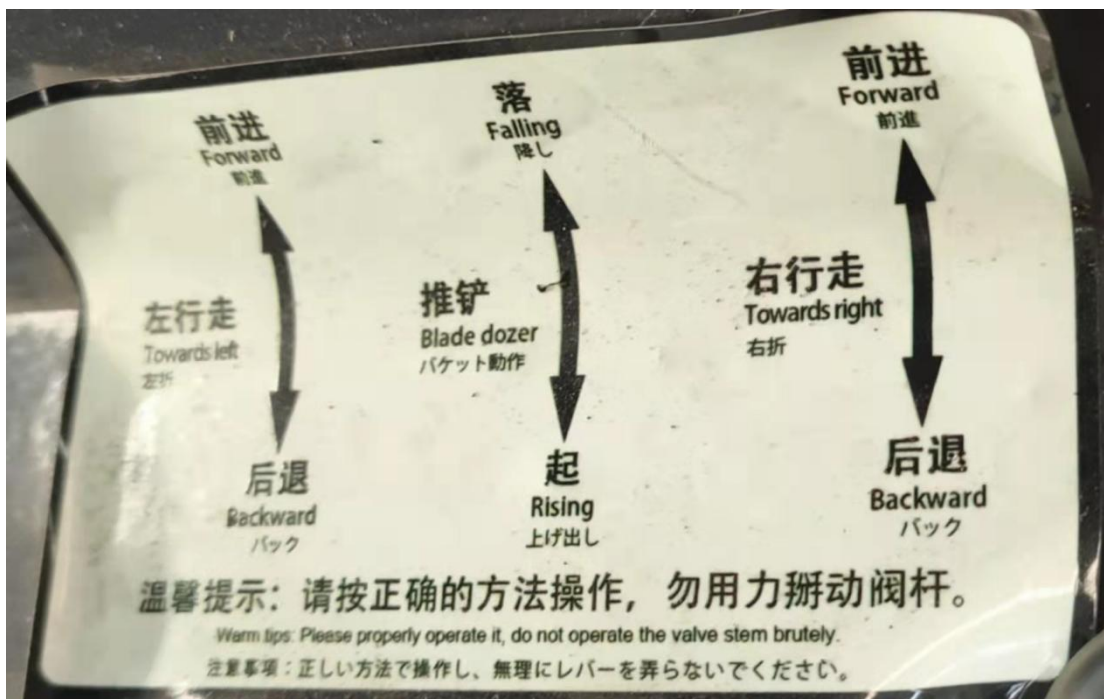
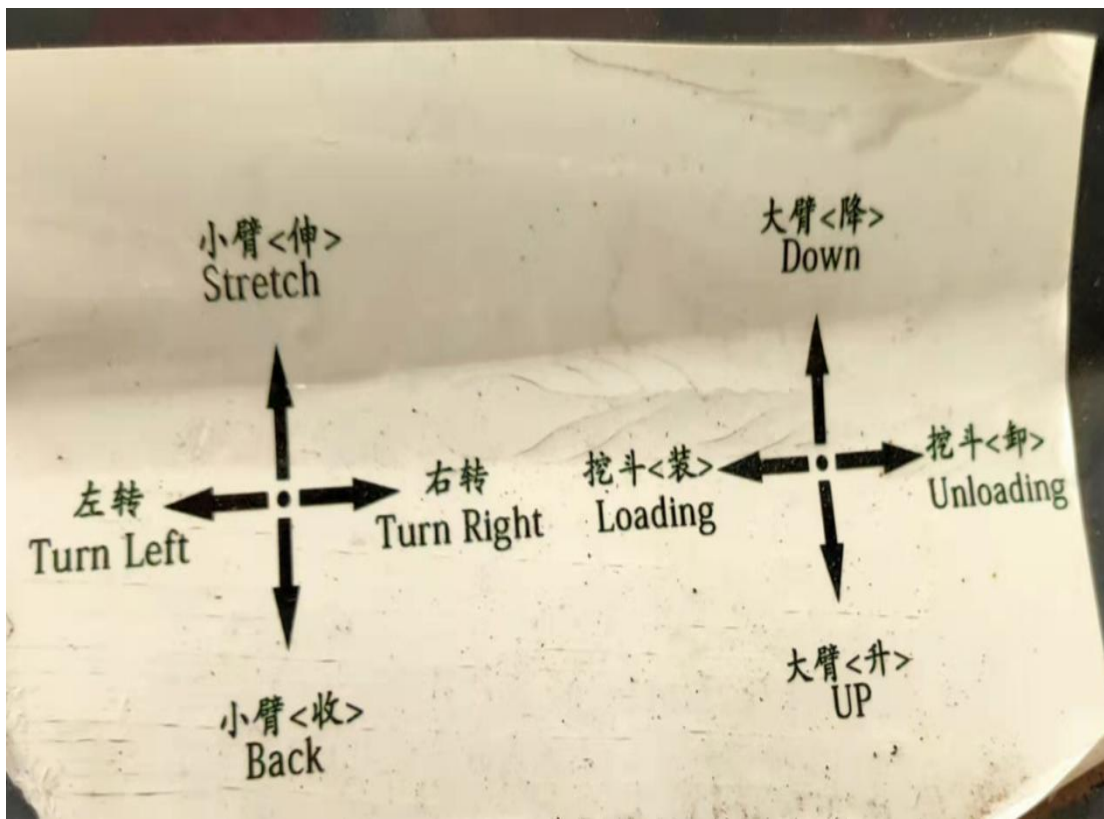

### 3.2 Bulldozer Operation Instructions

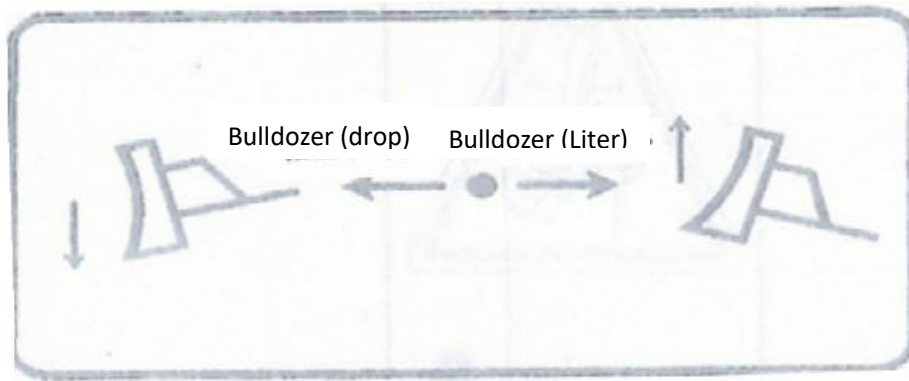

### 3.3 Instructions for walking

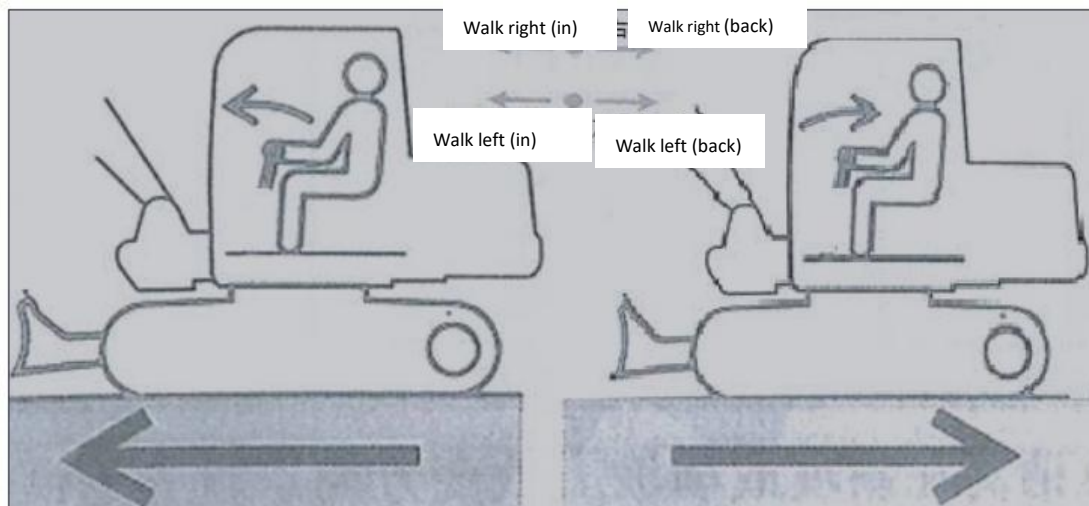

## Chapter 4 Precautions when doing homework

### 4.1 engine start

Before starting the engine, turn on the main power switch, add oil in an appropriate amount, turn the start switch, press the decompression switch after the engine speed reaches, release the start key immediately after the engine catches fire, and confirm whether the key springs back.

※It is strictly forbidden to turn the key again after the engine is started. This operation will damage the starter motor and the engine flywheel gear, and even damage the starter casing and burn the starter coil. In addition, excessively twisting the ignition key will cause the key not to rebound. After the engine is started, the starter gear cannot be separated from the engine. When the engine is driven at high speed, the current in the starter increases rapidly, causing the coil to burn.

The starter key itself has a dust cap, which can effectively prevent dust, water and other substances from entering the inside of the key. Once impurities such as water enter the inside of the key, it will cause the lock cylinder to be stuck and not return or internal short circuit, which will damage the starter, so in rainy days Or in a humid environment with a lot of dust outside, avoid unplugging the key for a long time and park it. If you need to park, you must take protective measures for the key port.

Special attention: the gasoline engine still cannot start after the starter motor runs for 10 seconds, please wait for 15 seconds to start again (continuous operation of the starter motor for a long time will cause a lot of battery power consumption, and may also burn out the starter).

The manufacturer does not provide warranty for damage to the starter caused by the above reasons.

After starting the machine, make sure that the main power switch and the first gear of the key are turned on, otherwise the battery cannot be charged.

After starting the engine, perform the following operations and inspections in a place free of people or obstacles. If any fault is found, shut down according to the procedure and report the fault.

Check whether the instruments and alarm devices are working properly.

Check for noise.

Test the engine speed control.

Do not use ether or starting fluid on the engine. Starter fluid can cause explosion and serious injury or death.

## **4.2 ensure a good line of sight**

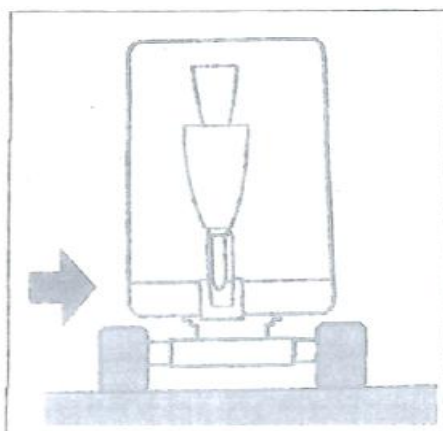

When working in dark places, turn on the machine's work lights and headlights, and install additional lighting if necessary.

When vision is poor due to inclement weather (fog, snow, rain or haze), stop operating the machine until vision improves.

#### **4.3 Do not put people on the machine**

When the machine is walking or operating, no one is allowed to ride on any part of the machine at any time.



## 4.4 Check that the work area is safe and secure before operating

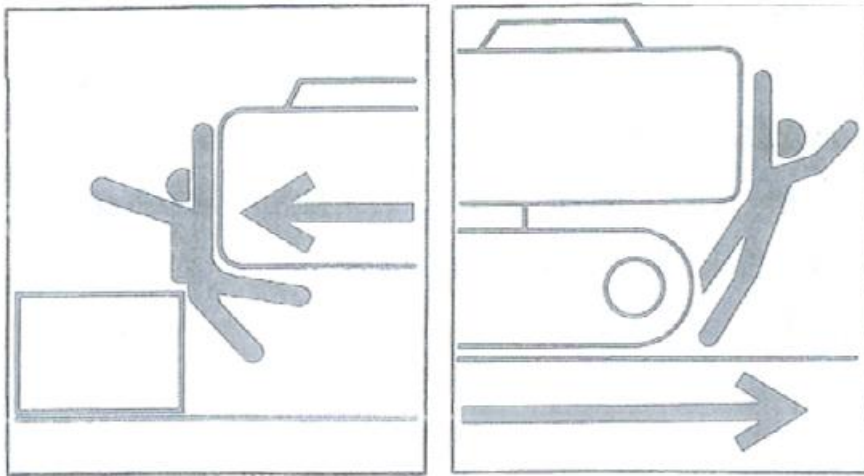

Confirm the performance limits of the machine.

Use a signaller on curbs, in narrow places, or where visibility is obstructed.

Never allow anyone to enter the machine's turning radius and path.

Signal your intention to move by honking your horn.

There is a blind spot for viewing angles behind the machine. Before walking backwards, check for safety behind you and make sure there is no one behind you.

## 4.5 Before walking, check the position of the lower frame (track)

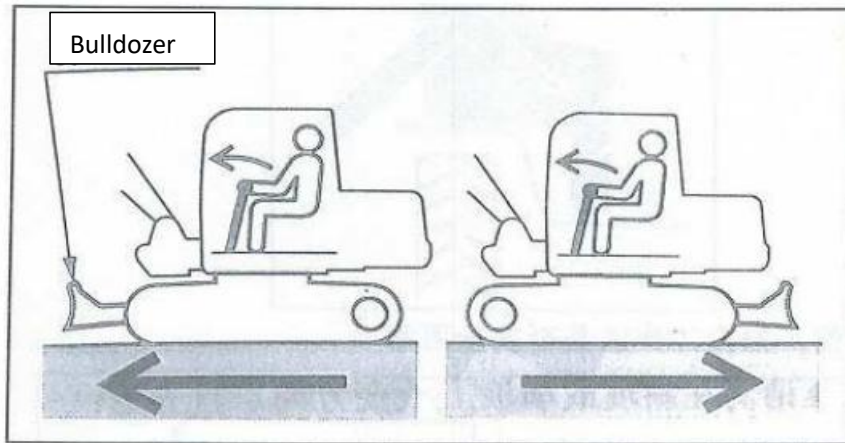

Before operating the travel lever/pedal, make sure the dozer is in front of the driver's seat, remember that when the dozer is behind the driver's seat, the travel lever/pedal must be operated in the same direction as when the dozer is in front of the driver's seat on the contrary.

#### **4.6 Precautions when walking**

walk safely

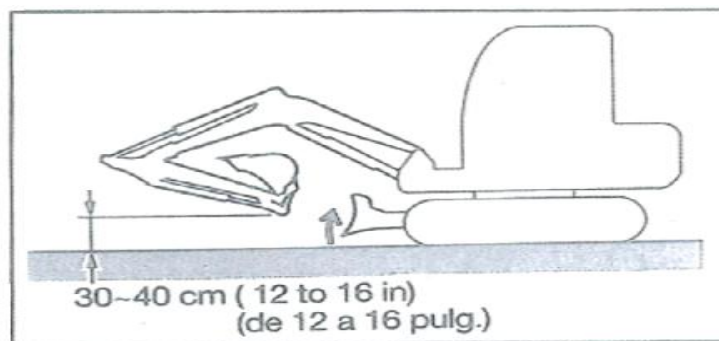

When the bulldozer is in the raised state, retract the bucket operation device as shown in the figure above, and raise the bucket to 30 cm to 40 cm above the ground.

When walking, do not turn around. If you must operate the bucket work equipment while walking, it should be slow enough to give you full control at all times.

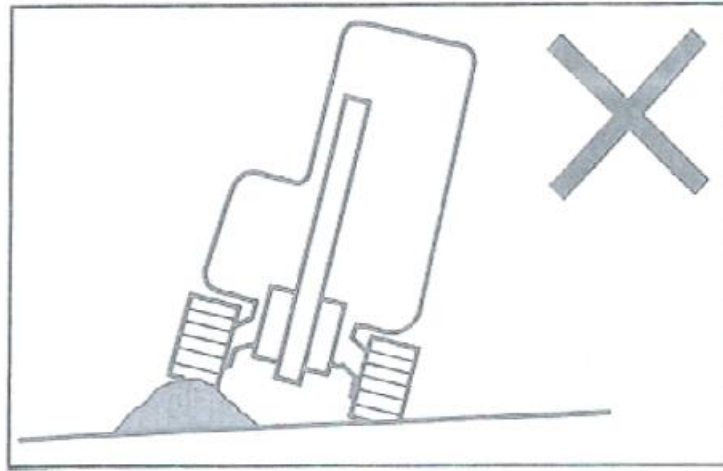

Try to avoid crossing obstacles. If you must do this, keep the bucket work unit close to the ground and walk slowly. Never go over obstacles that would tilt the machine 10° or more.

On uneven surfaces, keep walking at a low speed and avoid sudden starts, stops or changes of direction. Otherwise, the work equipment may come into contact with the ground, causing the machine to lose

Balance, damage or dismantle structures in the surrounding area.

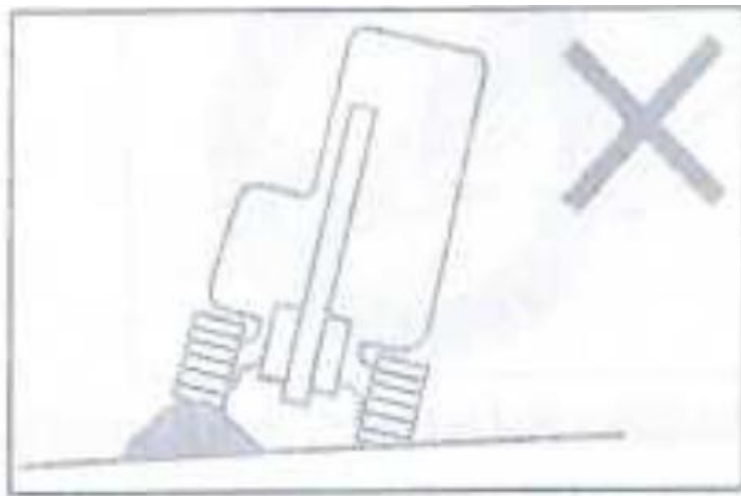

Walking on obstacles (rocks, tree stumps, etc.) may place a large load on the body and may cause damage to it, try to avoid over obstacles. If this is necessary, keep the bucket working unit close to the ground and travel at low speed so that the center of the track clears the obstacle.

### **Precautions when walking at high speed**



On uneven surfaces, keep walking at a low speed and avoid sudden starts, stops or changes of direction.

When walking at high speed, the bulldozer should be in front

### **Precautions when using this machine in water**



The rear of the machine must not be submerged in water. As shown in the picture above, the rear of the machine is immersed in water, which will cause the radiator fan to rotate in the water, resulting in damage to the fan.

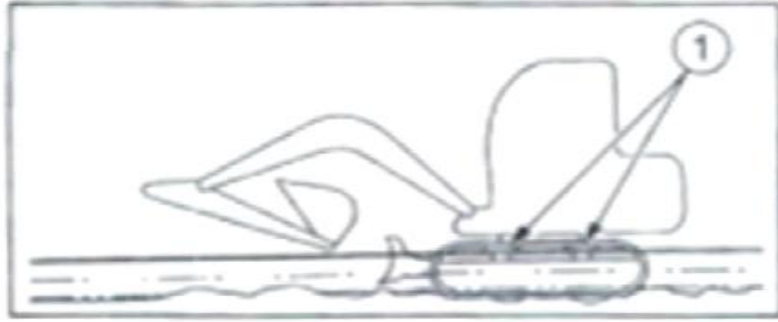

### **allowable water depth**

Use the machine in water only if the water does not exceed the middle of the track shoes.

Try to avoid working in water for a long time. Long-term operation will cause sediment or water to enter the inside of the walking motor, which will affect the normal use of the motor. For those parts used in water, add enough grease until the old grease is squeezed out.

Never immerse the slewing ring or body in water or sand. If it is submerged, please contact our service agent for inspection.

### **Out of the mud**

If the machine gets stuck in the mud, follow the steps below to get out.

### **If a track gets stuck in the mud**



1. Swing the bucket to the side of the track that is stuck in the mud.
2. Set the stick and boom angle from  $90^{\circ}$  to  $110^{\circ}$
3. Press the bottom of the bucket (not the teeth) to the ground.
4. Place a plank or similar object under the raised track.
5. Lift the bucket and slowly drive the machine out of the mud.

**If both tracks get stuck in the mud**



1. Perform steps 1 to 4 above for both tracks.

2. In front of the machine, dig the bucket into the ground.

3. Pull the stick when walking forward and move the machine out slowly.

### Precautions for walking on slopes

When walking on slopes or ramps, be careful not to overturn or slide the machine.

Never walk on steep inclines where the machine cannot maintain its stability (up to incline:  $30^{\circ}$  , bank angle:  $10^{\circ}$  ) Please note that in practice, depending on the operating conditions, the machine's stability may be lower than the above values .

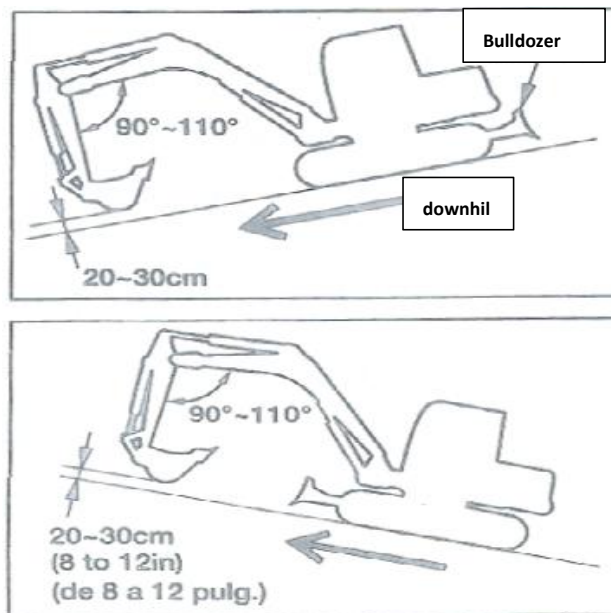

When climbing a hill, keep the driver's seat facing the hill. When going downhill, keep the driver's seat facing downhill. In both cases, attention must be paid to the ground in front of the machine when walking.

When walking on slopes, lower the bucket 20cm to 30cm above the ground. Extend the bucket work unit to the front when climbing steep grades. In an emergency, lower the bucket to the ground and turn off the machine.

When walking on an incline or ramp, drive slowly at a low speed. When going down a slope, reduce the engine speed.

### **Do not back downhill**

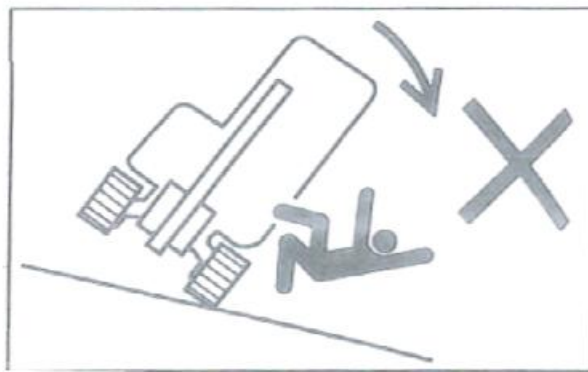

Do not change direction on slopes or cross slopes. Return to flat ground first, then choose another path.

The machine may slide sideways when walking on gentle slopes covered with grass or dead leaves, or on wet sheet metal or frozen ground. Make sure the machine is not parked sideways on the slope.

If the machine stalls on a slope, return the levers to neutral and restart the engine.

Use extreme caution when operating the machine on snow or ice.

When walking on snow or icy ground, drive at a low speed and avoid sudden starts, stops or changes of direction.

In snowy areas, objects placed on the shoulder of the road and by the roadside are buried in the snow and cannot be seen. There is also the risk of the machine tipping over or hitting covered objects, so always handle it with care.

If the machine enters thick snow, there is a danger of overturning or burying in the snow. Drive carefully and do not go over the shoulder or get trapped in snow.

Also pay special attention to high-voltage cables buried in the ground.

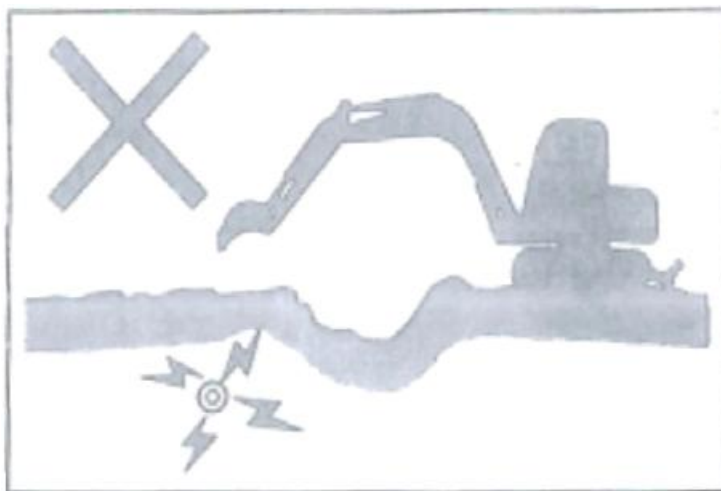

Pay close attention to hazardous working conditions

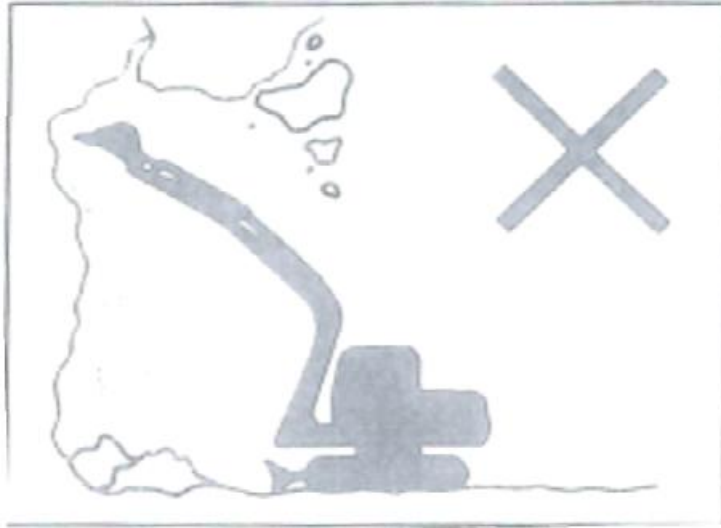

Never dig at the bottom of a high embankment. Doing so can cause the ground to collapse and is therefore dangerous.

Do not operate where there is a danger of falling rocks.

Maintain a safe distance between the machine and the edge of the excavation site and do not dig the ground in front of the machine.



When working close to a cliff or road shoulder, in order to make it easier to escape when there is a problem, during operation, make the crawler at a right angle to the cliff or road shoulder, and place the bulldozer in front.



Do not enter areas with loose floors. Doing so may cause the machine to tilt due to its own weight, causing it to overturn or sink to the ground.

Do not approach unstable ground (cliffs, shoulders, deep trenches). If the ground collapses due to machine weight or vibration, there is a risk of the machine falling or tipping over.

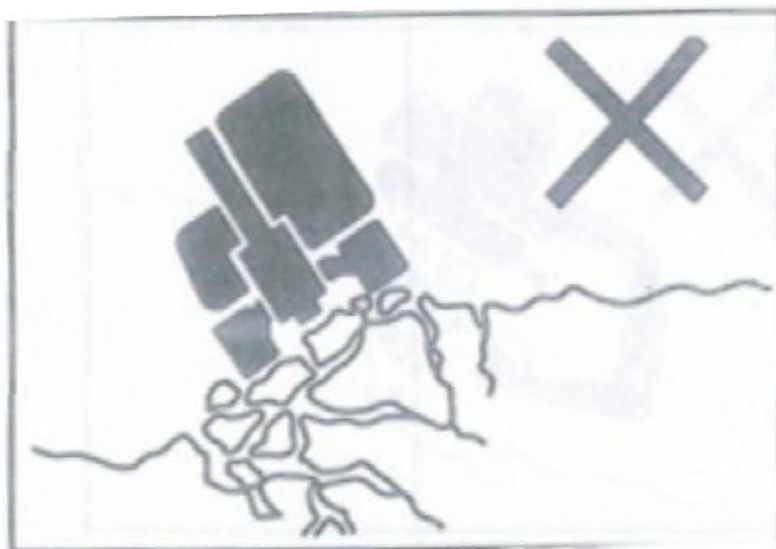

Remember that soil is not firm after heavy rain or blasting.

Ground such as the tops of embankments and around excavated ditches is also not strong.

Do not carry out disassembly work under the machine. As the ground becomes unstable, there is a risk of the machine falling.

#### 4.7 Excavation work precautions

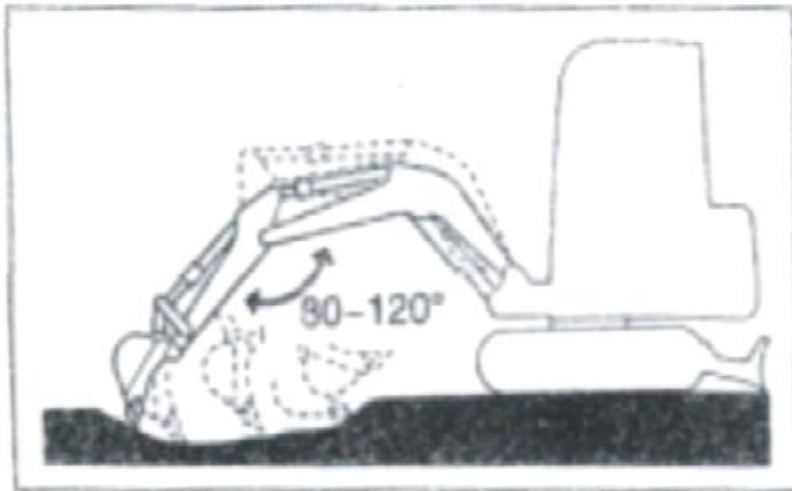

1. Position the blade on the opposite side of the excavation area.

2. When digging with a stick and bucket, the digging depth should be shallow and the stroke should be long. Boom and stick angle from  $80^{\circ}$  to  $120^{\circ}$  for maximum digging force. This angle should be used for effective excavation.

※When excavating media with rocks, place the bulldozer behind the excavator to prevent the rocks lifted by the bucket from hitting the cylinder of the dozer and causing the oil pipe to break. The resulting pipeline breakage is not guaranteed by the manufacturer.

## Dig trenches

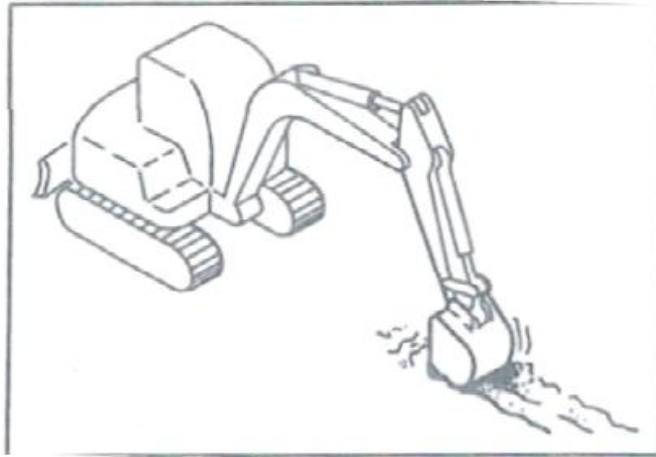

Install a bucket suitable for digging trenches and adjust the track to be parallel to the trench to be dug for greater efficiency.

When digging wide trenches, dig the sides first, then the middle.

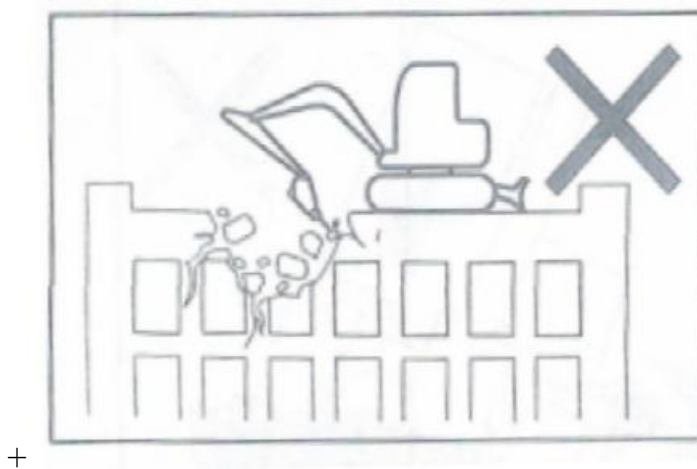

When working from the top of a building or other structure, check the strength and structure before operation. If a building or structure collapses, serious injury or damage can result.

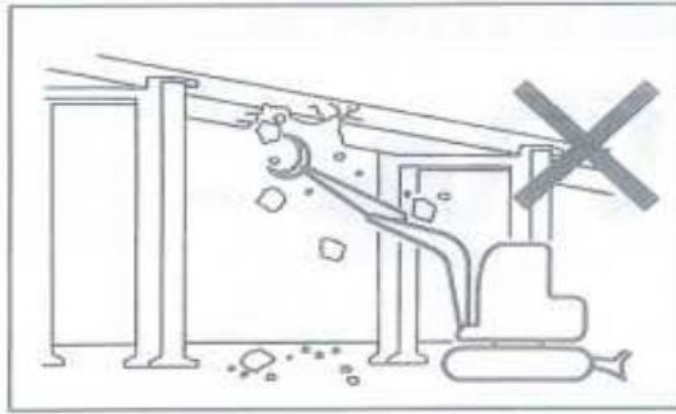

When dismantling, do not dismantle overhead. There is a risk of a broken part falling or a building collapsing, causing serious injury or damage.

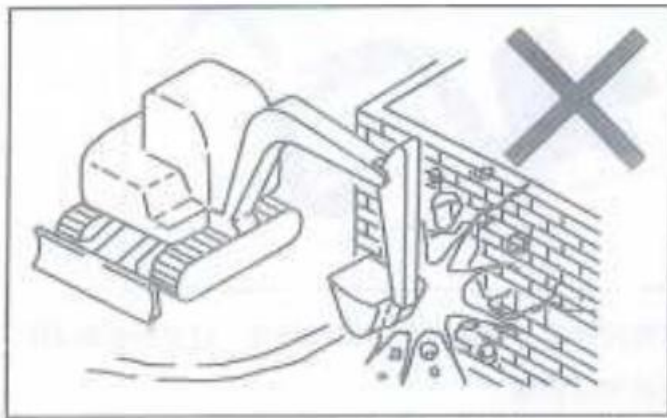

Do not use the impact force of bucket work equipment for demolition work. There is a risk of serious injury from flying material fragments and damaged bucket work equipment.

※Ensure that there is enough space between the excavator and the obstacle when excavating. When working in a narrow space, the excavator body may collide with the obstacle, resulting in deformation of the body, breakage of the oil cylinder, breakage of the oil pipe, and the

above-mentioned parts. Damaged products are not guaranteed by the manufacturer.

### **Hazardous operation on slopes**

Swinging or operating work equipment while operating on slopes or ramps may cause the machine to buck and overturn. Operation on slopes should be avoided as much as possible.

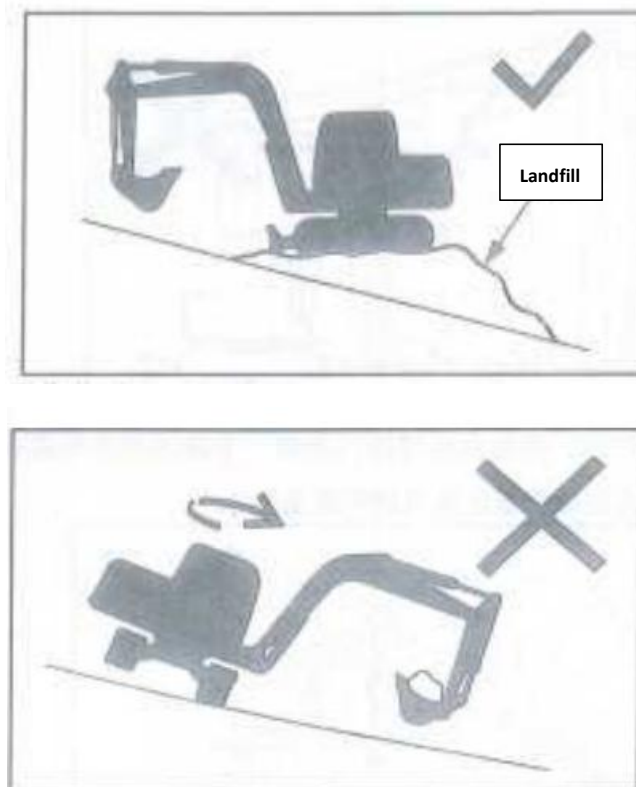

When the bucket is full of material, avoid turning downhill. This will reduce the stability of the machine and may lead to overturning.

Do not swing sideways (swing) when the bucket is heavily loaded.

The machine overturns more easily in the transverse direction than in the longitudinal direction.

Do not turn sideways (swing) when there is a heavy load on the end of the bucket work unit. In particular, do not turn sideways (wobble) on slopes.

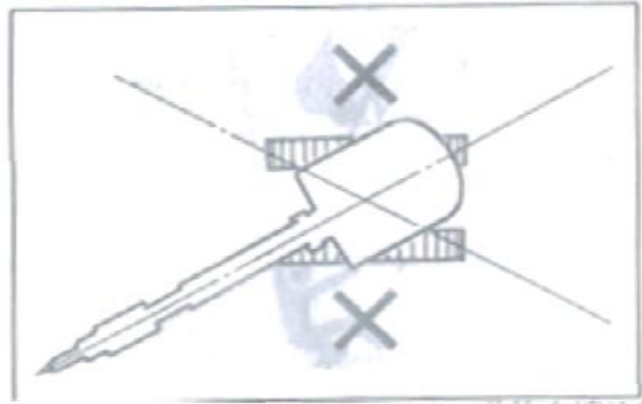

When the machine is equipped with a breaker, pulverizer or long stick, the attachment ends are heavier than when equipped with a standard bucket. Do not dig with the stick (boom) downhill or sideways on such heavy-ended machines.

**Pay attention to overhead objects**

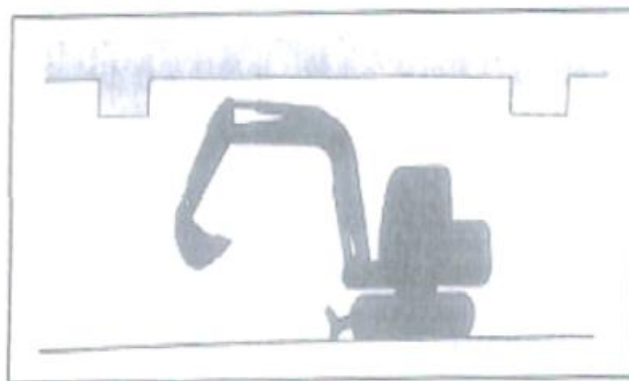

When operating under bridges, in tunnels, near electrical cables, or indoors, be careful not to strike the boom or stick against objects overhead.

#### **4.8 Precautions for leveling work**

The leveling should be done with a bulldozer, and it is forbidden to use a bucket to level by the rotation of the fuselage.

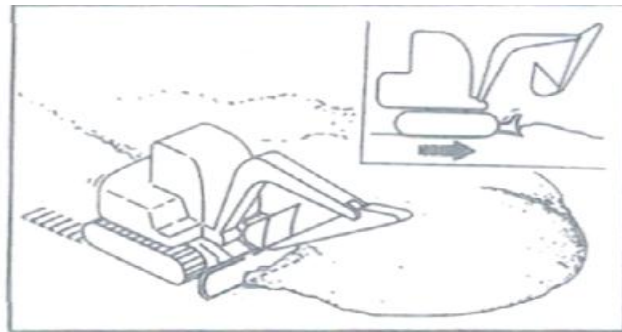

1. Move the bucket working device close to the machine.
2. Slowly push the soil away from the side of the mound.
3. When the mound is low, bulldoze from the top. If the load is too heavy for the body, raise or lower the blade to adjust.

#### **4.9 Precautions for hoisting operation**

Excavators are not designed for lifting, this machine is specially designed for excavation work. Therefore, it has no safety device for lifting operations. Special care should be taken if the excavator is used for lifting operations.



Do not overload the hoisting. Overloading can cause the machine to overturn, resulting in serious injury or death.

All rated lift capacities are based on using this machine on stable, level surfaces. For safe hoisting operations, users are expected to leave appropriate margins for specific working conditions. They include soft or uneven ground, non-level conditions, side loads, dynamic or sudden loads, hazardous environments and personnel experience. Before operating the machine, the operator and other personnel should be very familiar with the operation manual and should strictly observe the safety operation procedures of the equipment at all times.

If the chain or sling is not properly attached, the bucket linkage or sling may fail, resulting in serious injury or death.

When using this machine as a crane, do not attempt to pull tree stumps from the ground. The safety of the load acting on the machine in this use is unknown. Do not allow anyone to stand on or under hoisted objects or near the work area. Watch out for flying objects.

## **Chapter 5 Prohibited Behaviors During Homework**

Do not operate on bedrock (hard or soft).

When walking, do not turn around. If you must operate the bucket work equipment while walking, it should be slow enough to give you full control at all times.

●Do not use rotational force for disassembly, prying, or leveling.



●Do not use rotational force to dismantle walls or level the ground. Moreover, during the turning process, do not dig the bucket teeth into the ground. Doing so will damage the bucket work equipment and severely damage the swing motor, and swing gear. The resulting damage to the motor or slewing support will not be covered by the manufacturer's warranty.

●Do not dig while walking



- Do not dig the bucket into the ground and use the walking ability to dig.

Be gentle when using hydraulic cylinders

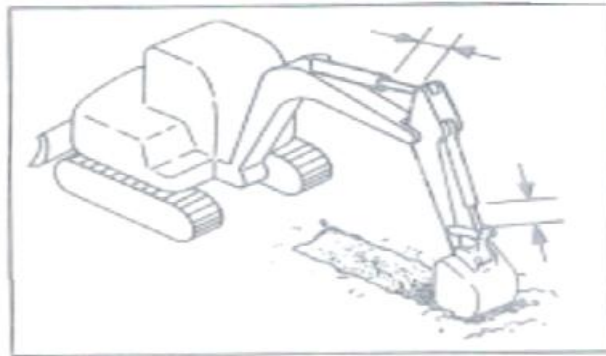

- Do not extend the hydraulic cylinder all the way. When operating, leave room for it.



Do not use bucket work equipment to support the body when the body is lowered and the stick cylinders are fully extended. Doing so will concentrate the load on the stick cylinder and may damage the stick cylinder.

- Do not push with the bucket or dig by thumping the bucket

Doing so will shorten the life of the bucket work equipment. Hydraulic pressure should be used for excavation.



● Do not prop up the machine and then turn it to change the direction of travel. This will impact the turning motor and gears, causing damage to the gears, and even overturning in severe cases.



● Do not use the sinking force of the machine to perform operations.



Putting extra tension on the machine will shorten the lifespan. When excavating, use the hydraulic pressure of the

oil cylinder, the depth should be shallow and the stroke should be large.

●Dig the bedrock

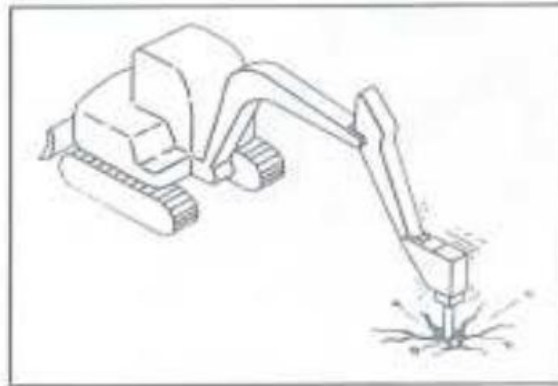

For hard bedrock. Before excavation, it is advisable to use a breaker or the like to break the rock into small pieces. In this way, damage to the machine is prevented and thus more economical.

More information about this original text To view additional translation information, you must enter the corresponding original text

**Pay attention to the impact on the bulldozer**



Hitting rocks, etc. with the blade will damage the blade and blade cylinder.

## Carefully retract the bucket work

When the bucket work device is stowed, be careful not to hit the bucket against the dozer blade.



● Do not use the bulldozer as a stand



Watch out for the bulldozer when digging



When digging deep, with the dozer ahead, be careful to avoid hitting the dozer with the boom and bucket.

When operating, try to keep the dozer blade as far back as possible.

**Use the bulldozer carefully to dig down**

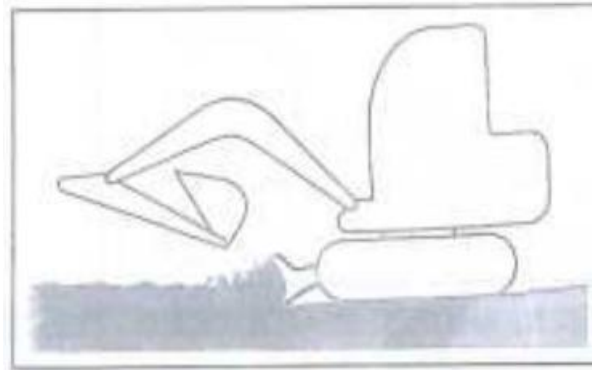

This dozer blade is designed for simple dozing operations. Do not dig deep with the bulldozer. Doing so may damage the dozer blade and lower frame.

### **Handling rubber tracks**

Due to the use of rubber, rubber has an inherent weakness, which is a lack of strength. Be sure to observe the following prohibitions and precautions to prevent track damage or disengagement.

### **ban**

Do not walk or operate machinery in the following locations:

Walking and turning on gravel, extremely rough and hard rock, steel beams, scrap iron, or near the edge of steel can damage the rubber track.



Walking on riverbeds or places with a large number of pebbles may cause stones to become trapped in the track, damaging the track, or causing the track to fall off.

Do not use this unit near the sea. Salt may corrode the steel core.



Do not allow fuel, lubricants, salt or chemical solvents to adhere to the track. These substances may corrode the steel core welds on the track and cause rusting or spalling. If any of these substances get on the track, they should be cleaned with water immediately.



If the machine walks on an irregular surface, such as a newly paved asphalt road, do not let the bucket hit the rubber track to cause damage to the track.

Be especially careful on snowy or frozen surfaces in winter, as the tracks are prone to slipping in such conditions.

Please use rubber tracks at temperatures between  $-25^{\circ}$  C and  $+55^{\circ}$  C.

When storing the rubber track for a long time (three months or more), please store it indoors in a place that is not exposed to direct sunlight or rain.



Since the entire track is made of rubber, rubber tracks are not as stable as steel tracks. Be especially careful when turning and swinging sideways.

### **Prevent rubber tracks from falling off**



Observe the following precautions to prevent the track from falling off.

Always keep the track properly tensioned.

When the vehicle is going to step over large steps such as cobblestones or rocks (20 cm or deeper), climb the steps at a right angle and do not change course on the steps.



When backing up a hill, do not change direction at the start of the slope.



Please avoid walking with one track on a slope or protrusion and the other on a flat surface (the machine is tilted at  $10^{\circ}$  or more), when both tracks are on a flat surface to walk.



Do not change direction when the track is slack as shown in the illustration.

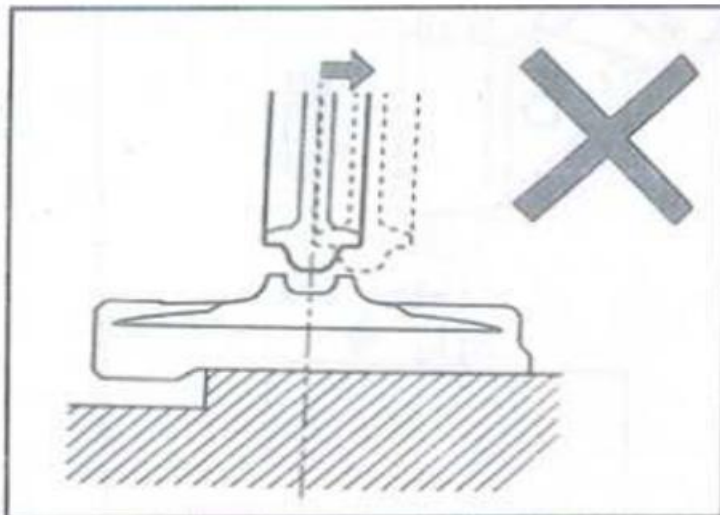

In this case, if the machine goes backwards, the rubber tracks will come off.

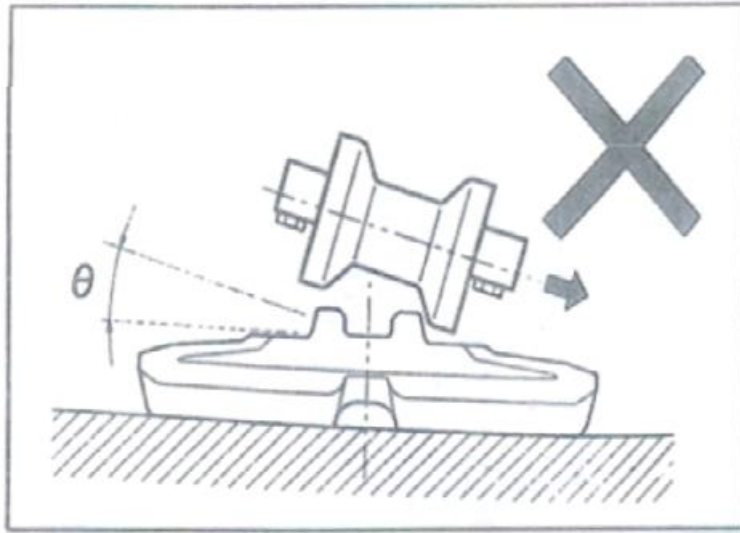

In this case, if the machine rotates, the rubber tracks will come off.

# Chapter 6 Hydraulic Breakers

## 6.1 Pressure measurement and inflation method

Generally, the breaker has been filled with nitrogen before leaving the factory. If the breaker works normally, no need to add air.

Refer to the following hydraulic breaker manuals for breaker operation.

Note: When installing the hammer head on the machine, you should ask how much nitrogen is suitable for the hammer head. The size of the model and the brand of the breaker may be different. The amount of nitrogen added to the hammer head is also different. The pressure is too high or too low. It may cause the hammer not to strike, or the hammer head stops working after the oil temperature rises.

**The nitrogen filling pressure of the L330 breaker is 1.4~1.6MPa.**

### **Nitrogen cylinders, tools**

Nitrogen bottle, nitrogen meter, wrench. This is the required tool, and it is best to take a photo with your phone before the nitrogen meter is taken out of the box, because when it is installed, it is always placed in the wrong position and cannot be installed well.



### Breaker Nitrogen Filling Port

The circled position in the picture is the nitrogen gas filling port. Before adding gas, clean the mud around the gas filling port and blow off the dust to prevent the screw from falling into the dirt after opening.



### Remove the air inlet

Use the inner hexagon to open the upper screw of the air inlet in a counterclockwise direction, and do not move the

lower screw. In this friendly reminder, "there is an O-ring on the removed screw, don't lose it".

The disassembled photos are as follows:



Use a pressure gauge to measure the residual nitrogen pressure

After installing the nitrogen meter, start to measure nitrogen, but before measuring nitrogen, make sure that the screws of ring 2, ring 3 and ring 4 are all locked. If they are not locked, the nitrogen inside the hammer body will leak cleanly. When nitrogen is used, press down ring 1 and check the reading of the pressure gauge. The value displayed by the pressure gauge is the internal pressure of the hammer body. After measuring the air pressure, lift up the ring 1 to prepare for the next step.



Ready to add nitrogen



1. First open the screw of ring 3, the pressure inside the nitrogen meter will return to zero at this time.

2. Then unscrew the cap of ring 2 (note: there is an O-ring inside, do not lose it, otherwise it will leak when you add nitrogen).

3. Connect the gas pipe to the nitrogen bottle and the ring 2 interface.

add nitrogen

At this point, the line is connected, check whether the joints are tightened, and all steps are ready, pay attention to the circle 1 in the picture, the needle must be lifted before inflating, and slowly open the nitrogen bottle valve [Special attention: nitrogen bottle pressure It is very high and cannot be opened quickly, otherwise the pressure will increase instantly, causing the pipeline to explode, and even endangering personal safety], open it slightly and then turn it off, and cycle in turn. During the process of adding, you should look at the hands at any time to reach the required pressure. , once the required pressure is exceeded, it needs to be deflated.

#### Degas after adding more nitrogen

When too much nitrogen is added, first close the valve of the nitrogen bottle, open the ring 3 screw, tighten the ring 3 screw after deflation, and then press down the ring 1 thimble. After the thimble bounces up, observe the pointer of the pressure gauge. If the pressure is still higher than the setting When the value is set, repeat the above operations until the nitrogen pressure reaches the standard, disassemble the meter head, and complete the inflation.

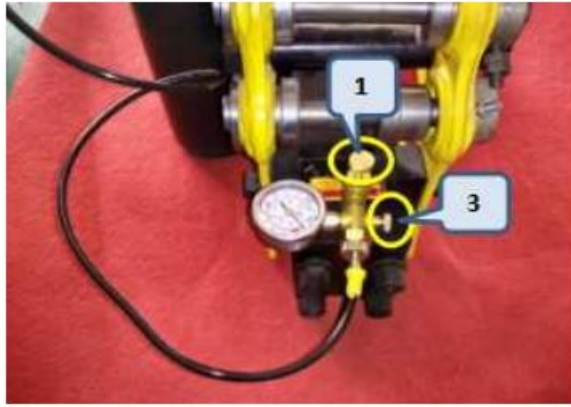

When using a breaker, in order to prolong the life of the hammer body, grease must be added to the designated grease port, otherwise the hammer rod may be stuck or excessively worn. The resulting damage to the components will not be covered by the manufacturer.

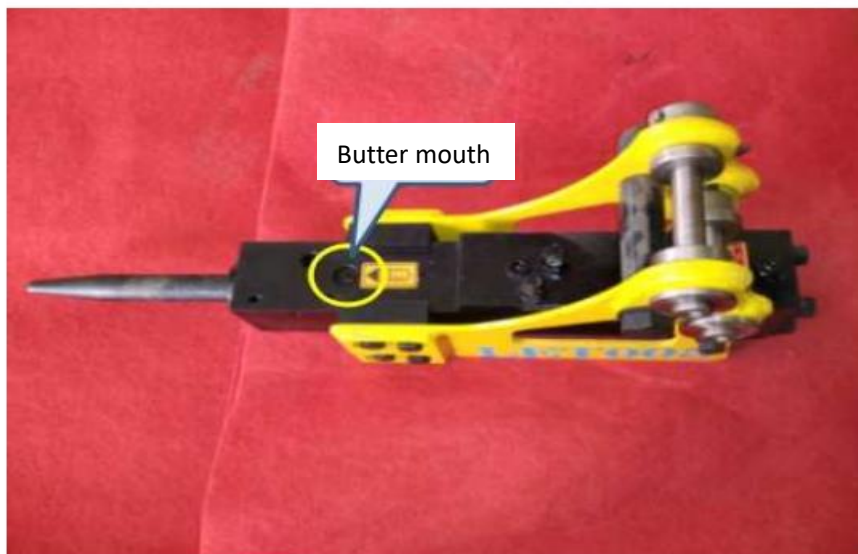

When installing options such as breakers, tilting buckets or grapples, make sure they are suitable for the model of machine you are using.

When choosing accessories, please contact your sales or service agent.

## 6.2 Installing and removing drill rods

Stop pins, locking pins and pitching rods are required for installation and removal of drill rods, see figure below.

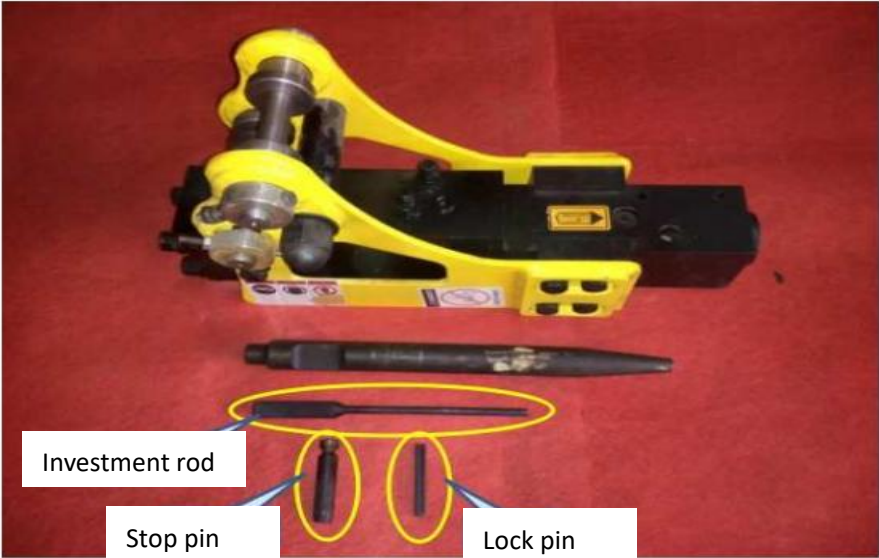

The method of installing the drill rod: first, put the groove side of the drill rod into the breaker with the hole of the stopper pin, and then insert the stopper pin (so that the end face of the cutout end of the stopper pin is flush with the surface of the breaker), and then smash the lock pin into the hammer. The rod is installed.

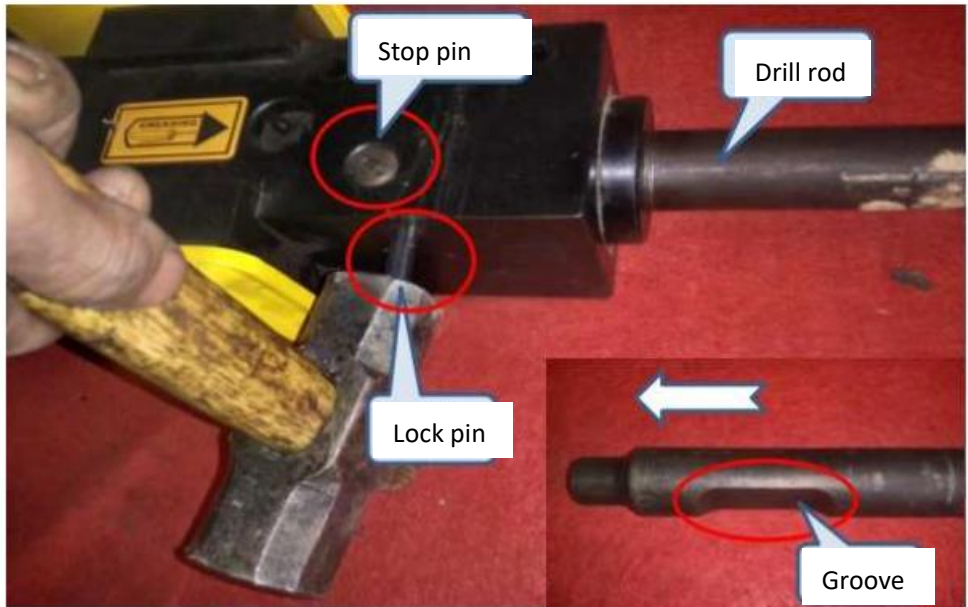

The method of removing the drill rod: insert the casting rod into the other side of the lock pin hole, hit the casting rod with a hammer, smash the lock pin out, then take out the stop pin, pull out the drill rod, and the drill rod is disassembled.



**6.3 Precautions for use of breaker**

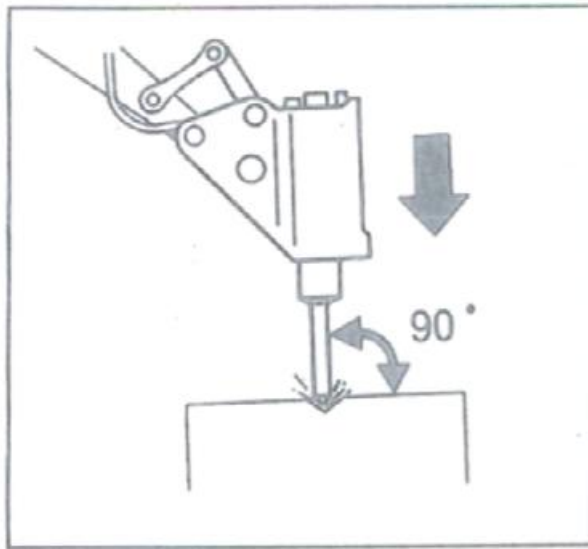

Use the hammer head to be perpendicular to the work surface for crushing. When crushing, the hammer head should be properly aimed at the crushed object to avoid hitting the air.



Do not pry with a hammer, and do not pry when broken. Do not move the hammer while breaking. On the same surface, do not continue impacting for more than 30 seconds.



Do not crush when the cylinder is fully extended or fully retracted (end of stroke). Leave at least 50mm clearance.



Do not crush when the stick is placed perpendicular to the ground.



Do not crush the object to be crushed by the fall of the breaker itself.

Do not use the breaker to move objects or rocks to be broken.

Swing the machine from time to time to cool the engine.

If the hydraulic pipe vibrates abnormally, the nitrogen gas in the accumulator may be leaking. Please check as soon as possible.

# Chapter 7 Shutdown and Transportation Precautions

## 7.1 Considerations when shutting down

### Safe parking

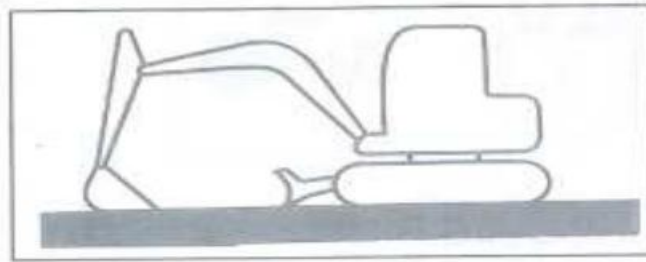

Park the machine on a level, firm and safe surface and set the parking device.

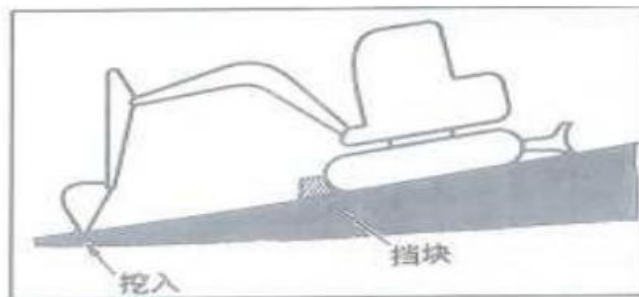

If it is necessary to park on a slope or tilt the body, park the machine securely and stop the machine from moving.

When parked on the street, grilles, warning signs, lights, etc. should be used to make the machine easy to see even at night and avoid collision with other vehicles.

**Before leaving the machine, do the following:**

Lower the bucket and dozer blade to the ground.

Turn off the engine, turn off the headlight switch and the main power switch (otherwise, it may cause a power loss in the frequency, and the machine cannot be started again)



## 7.2 Precautions when transporting

### Safe loading/unloading of machines

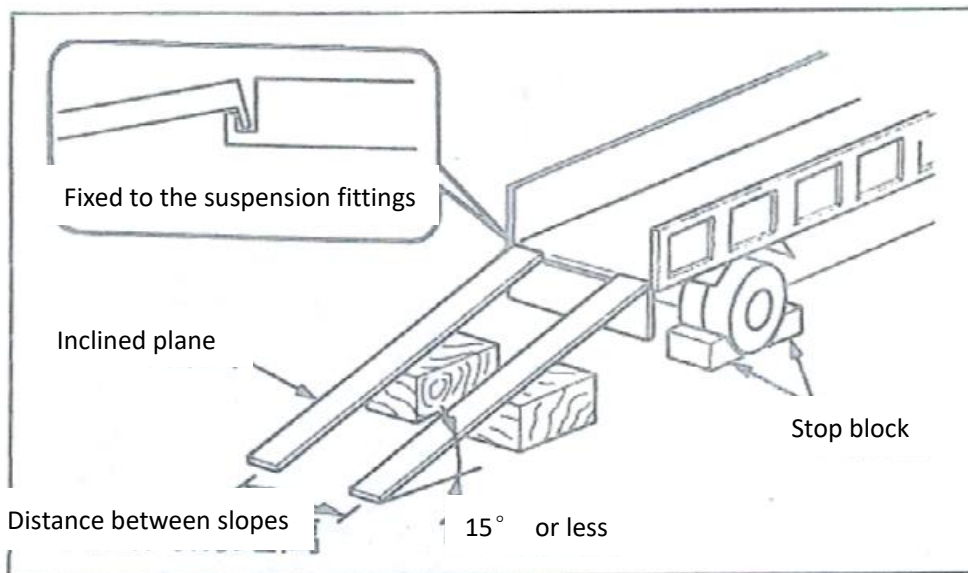

During loading and unloading, the machine may tip over or fall. Please take the following safety measures:

(1) Choose a solid and flat ground and keep a sufficient distance from the road shoulder.

(2) Fix the inclined plane with sufficient strength and size to the truck bed. The slope of the slope must not exceed  $15^\circ$ . If the ramp bends down too much, support it with struts or chocks.

(3) Do not use the working device to load or unload the machine. Doing so may cause the machine to overturn or fall.

(4) Keep the truck bed and slope clean, free from oil, sand, ice, snow and other foreign objects to prevent the machine from sliding sideways. Clean the tracks.

(5) Cock the wheels of the transporter with chocks to prevent movement.

(6) When loading and unloading the machine, please follow the signal of the signalman and walk slowly in a low gear.

(7) Do not change the route on the slope.

(8) Do not turn/swing on the slope. The machine may overturn.

(9) When turning/swinging on the truck bed, the footing may not be stable enough, so it should be done slowly.

(10) If feasible, lock the door and cover after loading. Otherwise, it may open during transport.

(11) Fix the track with a wedge, and then fasten the machine to the truck bed with a cable or chain.

### **Safely lift the machine**

Master and use the correct lifting gestures.

Check lifting equipment daily for damaged or missing parts and replace if necessary.

When hoisting, use a cable capable of pulling the weight of the machine.

Hoist the machine as described below. Do not operate in any other way as this may cause the machine to become unbalanced.

Do not hoist when there is an operator on the machine.

When hoisting, please do it slowly to prevent the machine from overturning.

Keep all personnel away from the work area when lifting. Do not move the machine over people's heads.

# Chapter 8 Basic Parameters of Excavator

## 8.1 The name of the main structural parts of the machine

The name of the main structural components of the machine (L330 model)

NO	model	
1	Spur teeth	
2	side teeth	
3	bucket	
4	Link rod	
5	rocker	
6	Shovel bucket cylinder	
7	dipper	
8	The bucket pole cylinder	
9	swing arm	
10	Move the arm cylinder	
11	dozer blade	
12	Guide the wheel	
13	thrust wheel	
14	driving wheel	
15	track	
16	Rear cover	
17	Left shield	
18	seat	
19	handrail	

20	Fuel mouth key	
21	Push soil shovel rod	
22	display	
23	Start the key	
24	gas	
25	Chassis telescopic	
26	work light	
27	Pilot lock	

## 8.2 Machine hinge pin

### Machine hinge pin (L330)

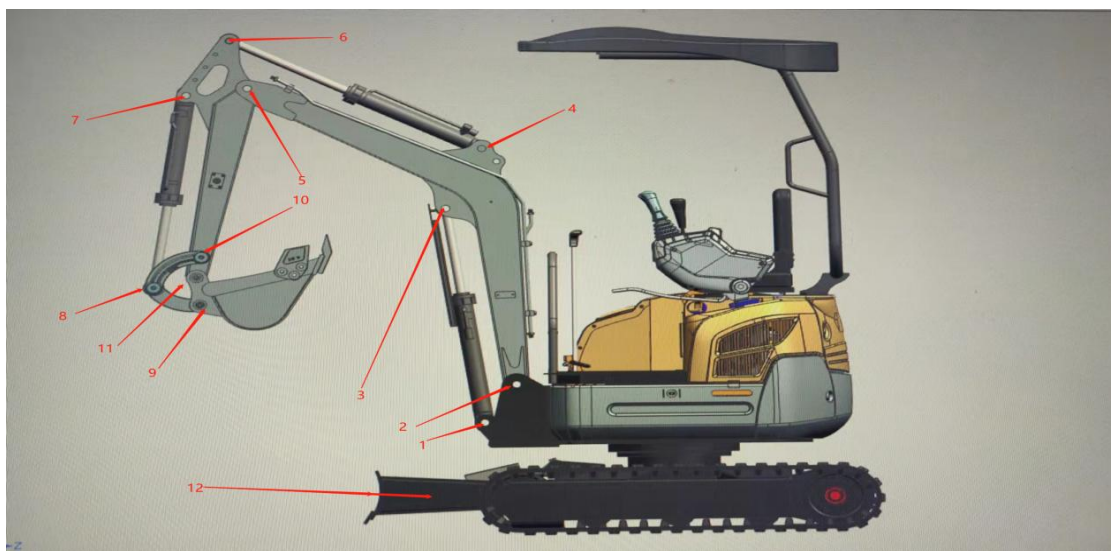

NO	Connect pin shaft
1	The boom / boom bracket connects to the pin shaft
2	The boom cylinder / boom bracket connects to the pin shaft
3	Arm cylinder / boom connects to the pin shaft

4	Bucket rod cylinder / boom connects to the pin shaft
5	The arm / bucket connects the pin shaft
6	The per cylinder / bucket connects the pin shaft
7	Bucket cylinder / bucket lever connects to the pin shaft
8	Bucket shaft cylinder / rocker / link connects the pin shaft
9	Connecting rod / bucket connecting the pin shaft
10	Bucper / rocker connects pin shaft
11	Bucar / bucket connects pin shaft
12	Motor arm bracket / upper frame connecting the pin axle
13	Tdozer cylinder / bulldozer connects pin shaft

### 8.3 Main Dimensions

#### Main Dimensions (L330)

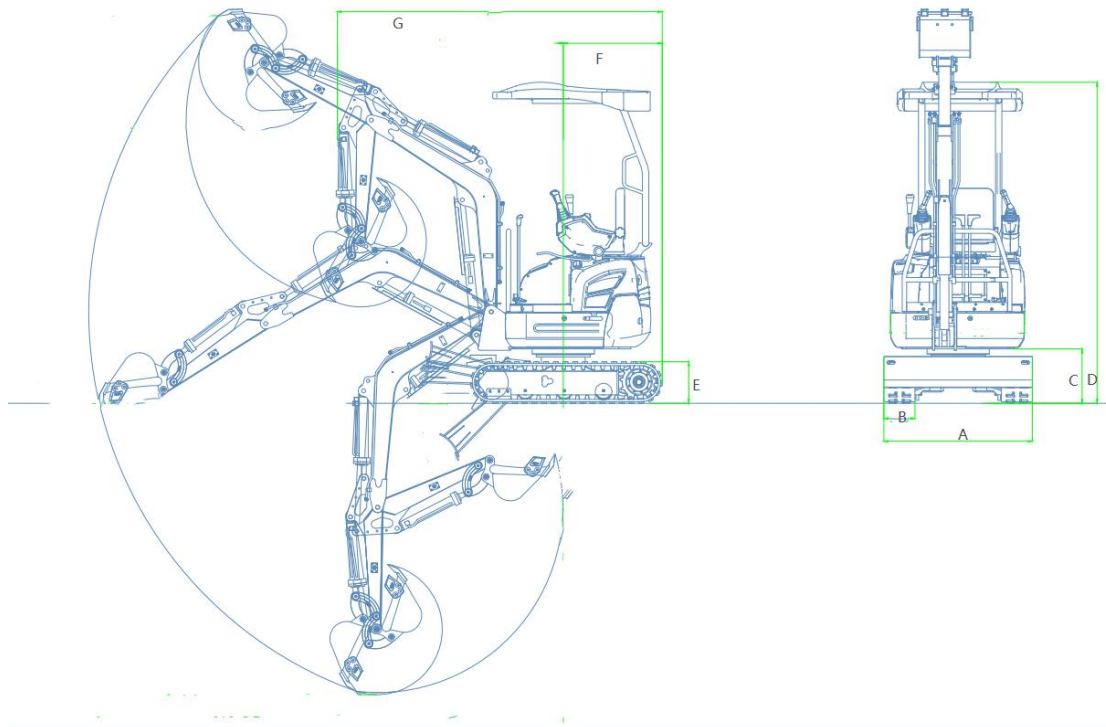

Machine size		unit: mm
		<b>L330</b>
A	Bottom width	1100

B	Track width	230
C	The platform is off the ground	402
D	Full vehicle height	2375
E	Track height	308
F	Platform rotation radius	732
G	Transportation length	2405

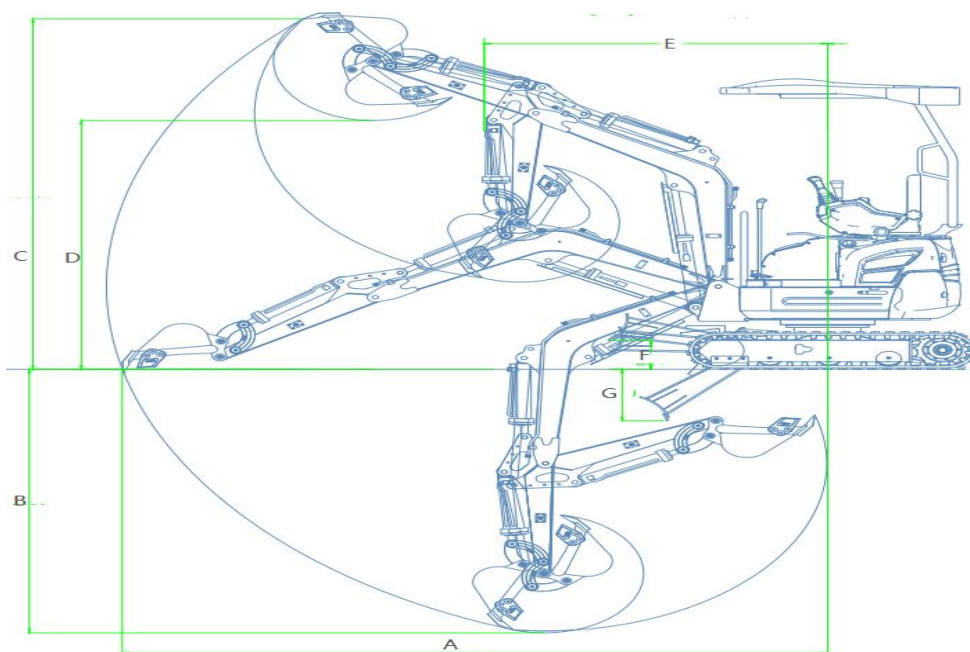

## 8.4 The scope of work

(L330)

Work range		unit: mm
		L330
A	Maximum ground excavation radius	3430
B	Maximum mining depth	2150
C	Maximum excavation height	2860
D	maximum dump clearance	2030
E	least radius of gyration	1673
F	Bullshovel maximum lift height	234
G	Bullaphoe for maximum excavation depth	420

## Chapter 9 Common Faults and Solutions

### Common faults and solutions of excavators

Common malfunctions	cause of issue	solution
The machine is weak and moves slowly	Overflow valve is blocked or too loose	Disassemble and clean or tighten the overflow valve
	Pump damaged	Replace hydraulic pump
	The oil pump inlet pipe is blocked	Clean or replace the oil inlet pipe
	Engine failure	Contact the manufacturer to overhaul the engine
The machine does not move	Pump damaged	Replace hydraulic pump
	Damaged coupling spline	Replace coupling spline
	The tilt of the fuselage causes the hydraulic oil to deviate.	Add hydraulic oil or level the machine
The machine can't rotate	Swing motor gear falls off	Install the slewing gear in place
	Swing motor is damaged	Replace the swing motor
The engine emits blue smoke and is weak	Overfilled engine oil	Adjust the amount of oil according to the upper and lower limits of the oil scale
	Engine failure	Contact the manufacturer to overhaul the engine
The engine emits black smoke and is weak	Air filter is clogged	Clean or replace the air filter
	Engine failure	Contact the manufacturer to overhaul the engine

Engine emits white smoke	Diesel mixed with water	Drain the oil and refuel
Engine holding the car	Overflow valve stuck	Remove the overflow valve and clean it with gasoline and reinstall it
	The overflow valve is adjusted too tightly	Loosen the relief valve
Engine does not fire	Insufficient battery voltage	Charge or use an external battery to catch fire
	Diesel fuel is refueled, causing air in the pipeline	Unplug the diesel pipe on the engine to drain the air and then install it or press the hand oil pump to drain the air
	Diesel freeze	Choose the right diesel grade according to the local temperature
	Engine failure	Contact the manufacturer to overhaul the engine
	Clogged fuel injector	Replace the fuel injector
	Air filter plugged	Replace the air filter
	Damaged high pressure oil pump	Replace the high pressure oil pump
	Fuse blown	Check and replace the fuse
	Electronic oil pump failure	Replace the electronic oil pump
	Damaged high pressure oil pump	Replace the high pressure oil pump
	The temperature is too low and the oil is too thick	Change the appropriate brand of engine oil
The engine throttle is up and down	Diesel fuel pipes are folded causing poor fuel supply	Check the diesel fuel pipe and adjust the direction to ensure smooth fuel supply
The throttle continues to increase	Engine throttle holder is locked	Loosen the engine throttle retainer
The throttle cannot be increased	The throttle cable sleeve is loose	Tighten the throttle cable sleeve

Common malfunctions	cause of issue	solution
Headlights do not light up, stopwatch or display does not work	The line plug falls off	Check whether the line plug is off or loose
	Damaged parts	Replacement parts
The battery does not charge	Broken generator wire	Check the engine wiring and reconnect it
	Broken fuse	Replace the fuse
	Damaged regulator	Replace the regulator
	Damaged battery	Replace the battery
Tracks fall off	The butter tensioner is not filled with butter regularly	Support the machine, remove the tensioner one-way valve, reinstall it after draining the oil, put the track into the tensioner and start the machine, use the rotating force of the drive wheel to install the track

		in place, and fill the tensioner with butter until Track tension.
Engine high temperature	Lack of antifreeze	Add antifreeze
	The radiator hole of the water tank is blocked	Clean the radiating holes of the water tank
	The thermostat is damaged	Replace the thermostat
	Plateau climate impact	Replace the high-pressure water tank cover
	Engine failure	Contact the manufacturer to overhaul the engine
Oil pressure alarm	Lack of oil	Add oil
	Engine overheated	Check the coolant
	The sensor is damaged	Replace the sensor
	Line fault	Check the route

A cylinder of the excavator cannot move do	Broken lever shaft or base	Replace the ball shaft or base, see chapter 9.2 for the disassembly method
The operating lever cannot be returned or pushed in place	Multiway valve stem return spring Set screw loose or falling off	Reinstall the return spring or tighten the fixing screw of the return spring. For the disassembly method, please refer to chapter 9.3
	Spool stuck	Refer to chapters 9.2 and 9.3, remove the spool, clean it and reinstall it

## 9.1 Installation of detached tracks

L330, installed after falling fall as follows:

Step 1: Remove the check valve on the tensioning device, and check the O-ring on the check valve for damage. If the damage occurs, the new O-ring must be replaced.

Step 2: Start the excavator, support the track before and after, make the excavator suspended, flameout and close the pilot lock handle.

Step 3: Remove the tug with an M18 wrench.

Step 4: Put the front of the track pattern toward the front of the excavator, and then install the front of the track on the tensioning wheel. One person presses the walking foot valve to rotate the motor backward, and the other person insttthe track back end to the top of the sprocket, and rotate the track based on the motor. Similarly, install the tracks on the other side.

Step 5: pry up the track with the crowbar and install the tug.

Step 6: Add butter to the track tension device until the track is fully tightened.

Special attention should be paid to safety in the above operation. Unjustified operation will lead to serious safety accidents (arms or clothes are involved, etc.). In the case of uncertainty, please contact the manufacturer for guidance.

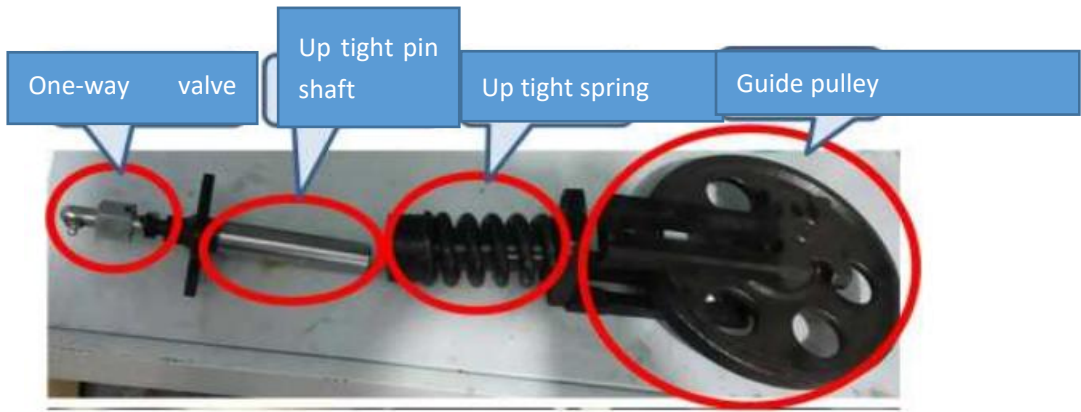

## **9.2 The engine cannot catch fire when the diesel fuel runs out**

The L330 excavator is equipped with a hand oil pump. When the fuel runs out, first unscrew the exhaust screw above the hand oil pump, and then press the hand oil pump for a while, and the air in the pipeline will be discharged clean. Then you can start the machine properly.

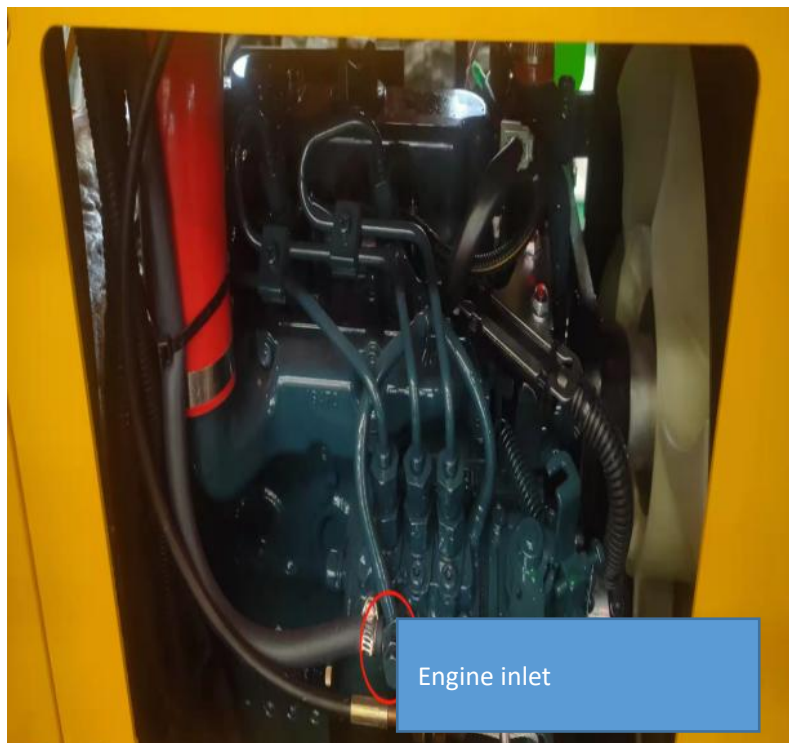

### 9.3 Replace the fuse sheet (wire)

The L330 excavator has 2 safety boxes, as shown in the figure below. The excavator seat cover plate needs to be opened first, and then

replaced.

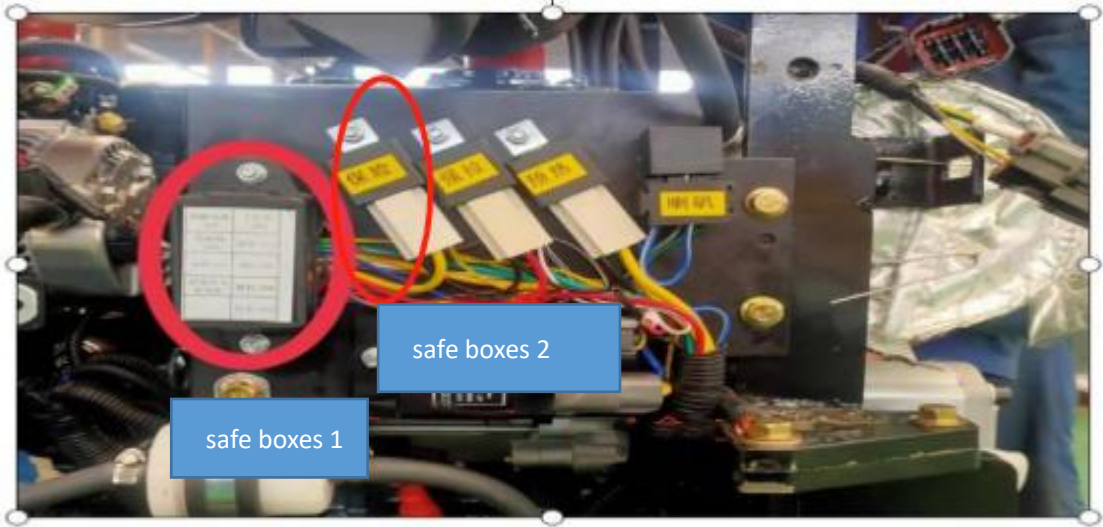

# Chapter 10 Maintenance and Maintenance

## 10.1 Maintenance Considerations

### engine maintenance

As the most important power system of the excavator, the engine needs to be maintained in accordance with the "engine instruction manual" carried on the vehicle.

Carrying out maintenance in strict accordance with the contents specified in the engine instruction manual can effectively improve the life of the engine and reduce the occurrence of failures.

The main maintenance contents mainly include the following parts:

1. Engine running-in period care.
2. Oil replacement cycle, and replenishment. (The oil will be consumed slowly with the use of the machine, so it is necessary to regularly check the amount of oil, not to wait until the next replacement after one filling, and to replenish in time when the oil is insufficient, otherwise it will cause serious consequences such as pulling the cylinder. Engine damage caused by lack of oil is not guaranteed by the manufacturer)

### 3. Air filter replacement cycle.

#### **"Do Not Operate" warning message**

Serious injury could result if an unauthorized person starts the engine or touches the control handle while checking or maintaining the machine.

Before maintenance, stop the engine, remove the key and take it with you.

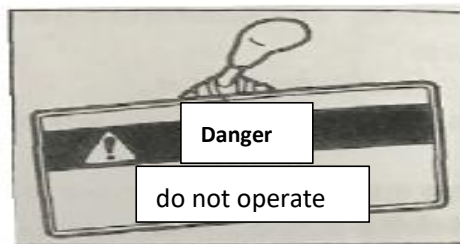

Display a "DO NOT OPERATE" warning message in a prominent place such as the starter switch or lever.

#### **Use the right tools**

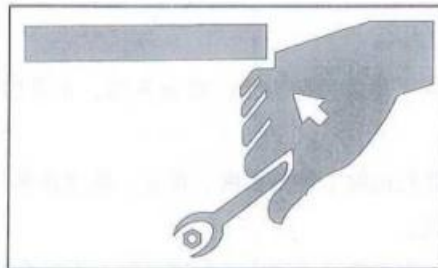

Do not use tools that are damaged or deteriorated or designed for other purposes. Use tools appropriate for the job in question.

#### **Regular replacement of safety critical components**

To ensure that the machine can be used safely for a longer period of time, it should be regularly refueled and inspected and maintained. For increased safety, replace safety-critical components such as hoses and seat belts regularly.

“Regularly Replaced Safety-Critical Component” means a component that ages, wears, and degrades function after repeated use, and whose performance changes over time. These characteristics of such components make it possible to cause serious mechanical damage or personal injury, and it is difficult to judge their remaining useful life based on visual inspection or handling alone.

Replace the “Regularly Replaced Safety-Critical Components” as soon as visual inspection of its appearance reveals any damage, even if the specified replacement interval has not been reached. Replace fuel hoses regularly. Fuel hoses wear out over time, even if they don’t show any signs of wear.

Replacement as soon as symptoms of wear and tear are noticed, regardless of the replacement schedule.

To use the machine safely, perform regular inspections and maintenance. The following safety critical components

must be replaced periodically to improve safety. Damage to these parts can cause serious injury or fire.

### Safety Critical Parts List

Body	Safety-critical parts that are regularly replaced		Replacement time
Fuel system	Fuel pipe		Every two years
	Packing on the fuel tank cap		
Hydraulic system	Host	Hydraulic hose ( Pump outlet )	Every two years
		Hydraulic hose ( Pump suction port )	
		Hydraulic hose ( Rotary motor )	
		Hydraulic hose ( Walking motor )	
	working equipment	Hydraulic hose ( Boom cylinder pipeline )	
		Hydraulic hose ( Stick cylinder line )	
		Hydraulic hose ( Bucket cylinder line )	
		Hydraulic hose ( Deflection cylinder pipeline )	
		Hydraulic hose ( Bulldozing cylinder pipeline )	
		Hydraulic hose ( Pilot valve )	
	Hydraulic hose ( Auxiliary pipeline )		

### Explosion-proof lighting



When checking fuel, lubricating oil, coolant, or battery electrolyte, use explosion-proof lamps to prevent

fire or explosion. Otherwise, an explosion may occur, resulting in serious casualties.

**Unauthorized entry is strictly prohibited**

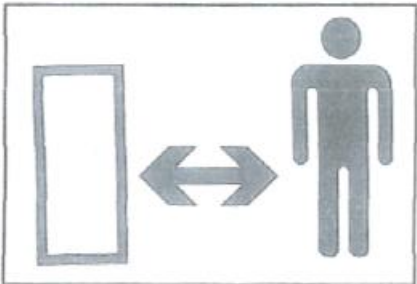

When working, do not allow unauthorized personnel to enter the work area. Be careful when sanding, welding or using a hammer. You may be injured by debris flying out of the machine.

**Work area preparation**

Choose a stable and level work area. Ensure proper lighting conditions, such as indoor operation, ventilation should be ensured. Clear obstacles and dangerous goods. Exclude slippery areas.

**Always keep the machine clean**

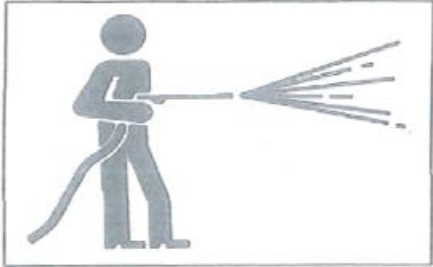

## **Before maintenance, the machine should be cleaned**

Stop the engine before cleaning the machine. Cover electrical components to prevent water ingress. Water entering electrical components may cause a short circuit or malfunction. Do not clean batteries, electronic controls, sensors, connectors or cab with water or steam.

## **Turn off the engine before maintenance**

Avoid lubricating or mechanically adjusting the machine when the machine is running, or when the machine is not running but the engine is running.

If maintenance must be performed while the engine is running, two people should be assigned to work as a team and communicate with each other.

A person must be in the driver's seat so that the engine can be turned off immediately if necessary. The person must take special care not to touch the levers and pedals, except when required.

Another person performing maintenance must keep their body or clothing clear of moving machine parts.

## **Keep away from moving parts**

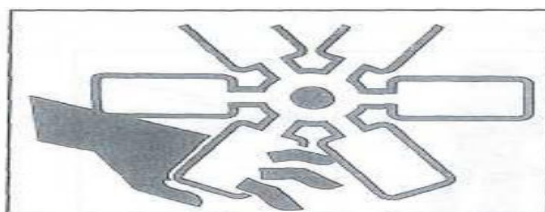

Keep away from all rotating and moving parts. Serious injury or even death can result if hands or tools get caught in rotating or moving parts.

If tools or other objects are dropped or inserted into the fan or fan belt, they can be blown or shredded. Do not drop or insert anything into the fan or fan belt.

### **Secure the machine or any parts that may fall**

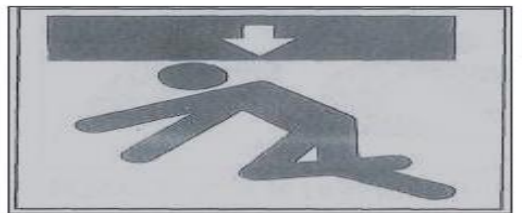

All movable work equipment should be lowered to the ground or in the lowest position before maintenance or repair is performed under the machine.

### **Fixed track**

If it is necessary to work under a raised machine or equipment, it must be secured with wooden blocks, jacks or other sturdy and stable supports. Do not get under the machine or work equipment until it is firmly supported. This procedure is especially important when working with hydraulic cylinders.

### **Stable working device**

To prevent unintentional movement of the machine, the working device should be fixed during maintenance and replacement of bucket teeth or side teeth.

Hold the hood or cover steady when you open it.

Be sure to secure the hood or cover before working inside the machine. Keep the hood or lid closed in windy weather or when the machine is parked on a slope.

**Place heavy objects in a stable position**



During disassembly or installation, when heavy objects or accessories need to be temporarily placed on the ground, be sure to place them in a stable place. Keep such items away from unauthorized persons.

## Refueling Notes



No smoking or open flames while refueling or near the refueling point.

Do not remove the fuel cap or add oil while the engine is running or has not cooled down. Do not spill fuel on hot surfaces of the machine.

Fill the fuel tank in a well-ventilated area.

Do not top up the fuel tank. There should be room for oil expansion.

Spilled fuel should be wiped up immediately.

Tighten the fuel tank securely. If the fuel tank cap is missing, replace it with the original one. Using an unapproved and poorly vented fuel cap will create internal pressure in the fuel tank.

### **Prevent dust from entering**

When installing and removing parts, do it in a dust-free place, sweep the work area and clean the parts to prevent dust from entering.

### **Clean the mounting surface**

When installing and removing parts, make sure that the contact surfaces of the parts are clean. If the sealing groove on the contact surface is damaged, please contact your sales or service agent for repair or replacement.

## Seals and cotter pins

Be sure to replace all removed seals and cotter pins with new ones.

When installing, be careful not to damage or twist the seal.

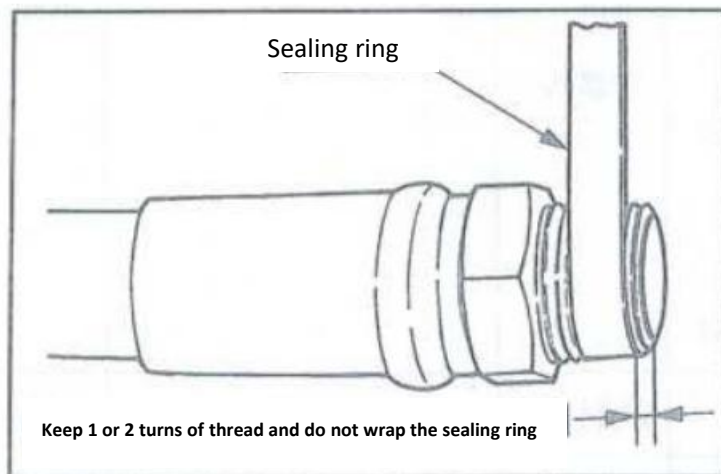

When wrapping plugs with sealing tape, clean the threads of the old sealing tape and wash the threads. Fuel must not be used for cleaning.

Tighten the threads with the sealing ring, taking care to leave 1 or 2 turns at the end of the plug unwrapped.

Fuel and Lubricants Use the correct fuel grade for the season.

Please select the appropriate fuel, lubricating oil and grease according to the temperature. Replace the oil if it becomes too dirty or deteriorated, regardless of whether the specified time has elapsed.

When refueling, do not mix different brands of oil. If changing brands, replace all fuel/lubricants.

## Fuel

Gasoline should meet the following standards, this table lists several current fuel specifications in the world.

Fuel specification	Location	Diesel specification	Location
GB252	China	BS2869-A1 或 A2	U. K
ASTM D975 serial number: 1-D, S15	America Canada	ISO 8217DMX	<u>internationality</u>
<u>Biodiesel</u> The <u>biodiesel</u> blend is B5 ASTM D6751, D7467			
EN590:96	European Union	JIS K2204 Class 2	Japan
<u>Biodiesel</u> The <u>biodiesel</u> blend is B5 ENI4214, EN590			

## Fuel tank

To maintain engine performance and longevity, always use clean, high-quality fuel.

To prevent freezing in cold weather, choose gasoline that is suitable for use when the actual temperature is at least 12° C below the expected minimum outdoor temperature.

Please use gasoline with a hexadecimal value of 45 or more. When used in alpine or high-altitude areas, fuel with a higher hexadecane value is required.

Use fuel with a sulphur volume ratio of less than 0.05~0.0015%. (In the United States or Canada, ultra-low sulfur fuel should be used.) The use of fuel with high sulfur

content may cause sulfuric acid corrosion of engine cylinders.

Kerosene is prohibited. Never mix kerosene, used engine oil or residual fuel with gasoline.

Poor quality fuel can reduce engine performance or cause engine damage. Fuel additives are not recommended. Certain fuel additives can cause a decrease in engine performance.

Metal content, such as zinc, sodium, silicon and aluminum, shall be limited to 1 part per million (1 mass ppm) or less.

Safety precautions when using biogasoline, the engine manufacturer's warranty is void for machines using biogasoline that does not meet standards or has deteriorated.

### **Handling of hoses**

1. Leakage of lubricating oil or fuel can cause fire.
2. Do not twist, bend or hit the hose.
3. Do not use twisted, bent or cracked pipes, metal pipes or hoses, otherwise they may burst.
4. Re-tighten the loose joint.

**Be careful when handling high temperature and high pressure components**

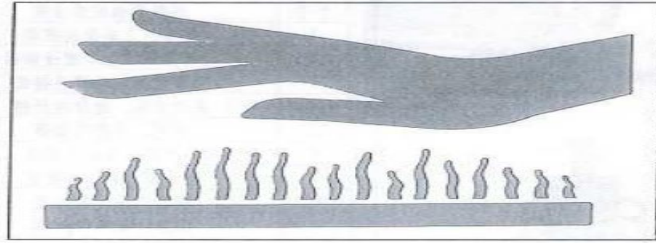

1. Please turn off the engine and wait for the machine to cool down before maintenance.

2. The engine, exhaust pipe, radiator, hydraulic pipe, sliding parts and many other parts of the machine are very hot when the engine is just turned off. Touching these parts can cause burns.

3. Engine coolant, hydraulic oil and other oils are also under high temperature and high pressure.

4. Be careful not to touch the hydraulic oil when loosening the cover or plug. Operating the machine in this condition could result in burns or injury due to hot oil spraying out.

**Be careful when operating high temperature cooling systems**

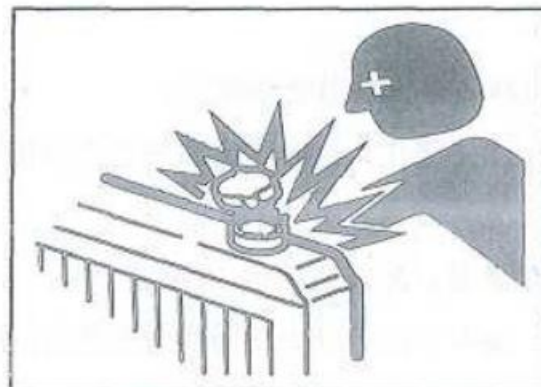

When the cooling water is hot, do not remove the radiator cap or drain plug. Stop the engine and wait until the engine and cooling water cool down. Then slowly loosen the radiator cap to relieve the internal pressure, and then remove it.

### **Be careful with oil pressure**



After the engine is turned off, the pressure in the hydraulic lines can be maintained for a long time. The internal pressure should be completely relieved before maintenance work.

The high pressure of hydraulic fluid can pierce the skin or eyes, causing serious injury, blindness or death. Remember that hydraulic oil seeping out of the small holes is almost invisible to the naked eye. When checking for leaks, wear sun protection goggles and thick gloves, and use cardboard or plywood to protect your skin to prevent injury from hydraulic fluid spray.

If hydraulic oil penetrates the skin, it should be surgically removed within a few hours by a physician familiar with such injuries.

**Before working on the hydraulic system, the pressure should be relieved**

Before the hydraulic system is depressurized, the hydraulic fluid may spray out if the cover or filter is removed or the lines are disconnected.

Slowly loosen the vent plug to relieve tank pressure.

When removing the plug or screw or disconnecting the hose, stand on one side and slowly loosen it to gradually relieve the internal pressure before removing it.

Oil or oil plugs may spray out due to the pressure in the travel motor tank. Loosen the oil plug slowly to release the internal pressure.

**Be careful of flying debris when using the hammer**

When using a hammer, pins or metal shavings may fly around. This could cause serious injury.

Wear protective equipment such as goggles and gloves when hitting hard metal parts such as pins, bucket teeth, side teeth or bearings with a hammer.

When striking the pins or bucket teeth, make sure that there is no one around.

## Disconnect the battery cable

Disconnect battery cables before working on electronic systems or welding. Disconnect the negative (a) battery cable first. When reconnecting, connect the negative (a) battery cable last.



## Be careful when handling batteries

The battery contains sulfuric acid, which can damage eyes or skin if touched.

In case of accidental contact with eyes, rinse immediately with water and seek medical attention immediately.

If swallowed, drink plenty of water or milk and seek medical attention immediately.

If sulfuric acid comes into contact with skin or clothing, wash it off immediately with plenty of water.

Wear goggles and gloves when handling batteries.

Batteries can generate flammable hydrogen gas, which may explode. Keep away from sources of ignition such as open flames, sparks or lighted cigarettes.

Use a flashlight when checking the electrolyte level.

Before checking or disposing of the battery, be sure to turn off the starter switch to stop the engine.

Be careful not to let metal tools or any metal objects touch the electrodes and cause a short circuit.

Electric sparks are generated when the electrodes are loose. Be sure to tighten it.

Make sure the battery cap is securely closed.

Do not charge or jump start the engine when the battery is frozen, or an explosion may occur. Warm frozen batteries to 15° C before use.

Do not use the battery when the liquid level is below the lower limit. Otherwise, the internal aging of the battery will be accelerated and the lifespan will be shortened. It can also rupture (explode).

Do not add distilled water above the upper limit. Otherwise, the electrolyte will leak out. Contact with this liquid can damage the skin or corrode machine parts.

Clean the area around the electrolyte level line with a damp cloth and check the level. Do not clean with a dry

cloth, as static electricity can build up and cause a fire or explosion.

### **Jump start with battery charging cable**

When starting the engine with the battery charging cable, be sure to connect the cable in the correct procedure below. Incorrect cable connection can cause discharge and battery explosion.

Don't let the "problem machine" and the "rescue machine" bump into each other.

Do not touch the positive (+) and negative (-) clips of the battery charging cable together or touch the machine.

To connect, first connect the positive side of the battery charging cable to the positive (+) terminal. To disconnect, first disconnect the negative cable from the negative (-) terminal (ground).

### **Be sure to attach the clip securely.**

Connect the last clip of the battery charging cable as far away from the battery as possible.

Goggles and gloves should always be worn when starting the engine with the battery charging cable.

Use battery charging cables and clips sized for the capacity of the battery. Do not use damaged or corroded battery charging cables and clips.

Make sure the "Rescue Machine" battery has the same capacity as the "Problem Machine" battery.

### **Please entrust our service agent for welding repair**

When welding must be carried out, it must be carried out by qualified personnel in a well-equipped workplace. To prevent damage to any part of the machine due to excessive current or sparks, observe the following.

The battery wiring should be disconnected before welding.

Do not continuously apply 200V or more.

The grounding point must be connected within 1 meter from the welding site. Do not connect the ground terminal near electrical controls/meters or connectors.

Make sure that there are no seals or bearings, etc. between the welding part and the ground terminal.

Do not connect ground terminals around work equipment pins or hydraulic cylinders.

When welding the machine body, disconnect the connector of the electric control device before the operation.

### **Shock to the operator**

Test results on vibrations transmitted by the machine to the operator show that the vibrations experienced by the upper limbs of the operator are less than  $2.5\text{m/s}^2$ , and the

vibrations experienced by the body in the seat area are less than  $0.5\text{m/s}^2$ .

## Waste disposal



Make sure to collect waste oil from the machine in a container. Improper disposal of used oil can be harmful to the environment.

Follow applicable laws and regulations when handling hazardous objects such as lubricants, fuels, coolants, solvents, filters and batteries.

## Handling of Hazardous Chemicals

Direct contact with hazardous chemicals can cause serious injury.

Hazardous chemicals used in this machine include grease, battery electrolyte, coolants, paints and adhesives.

Please handle hazardous chemicals carefully and properly.

## 10.2 Lubrication part diagram

Lubrication part diagram (L330)

L330 models have a total of 16 fuel filler ports (excluding left and right track tensioner fuel filler ports)

grease nipple location	quantity
(1) The connection between the left and right legs of the bulldozer and the bottom plate [1 2]	2 butter nipples
The connection between the non-rod end of the bulldozer cylinder and the bulldozer, and the connection between the rod end of the bulldozer cylinder and the lower plate [3 4]	2 butter nipples
(2) The connection between the boom bracket and the boom [1]	1 butter nipple
(3) Boom cylinder 【1 2】	2 butter nipples
(4) Stick cylinder 【1 2】	2 butter nipples
(5) The connection between the boom and the stick [1]	1 butter nipple
(6) Bucket cylinder 【1 2】	2 butter nipples
(7) At the rocker and at the connecting rod [1 2 3 4]	4 butter nipples

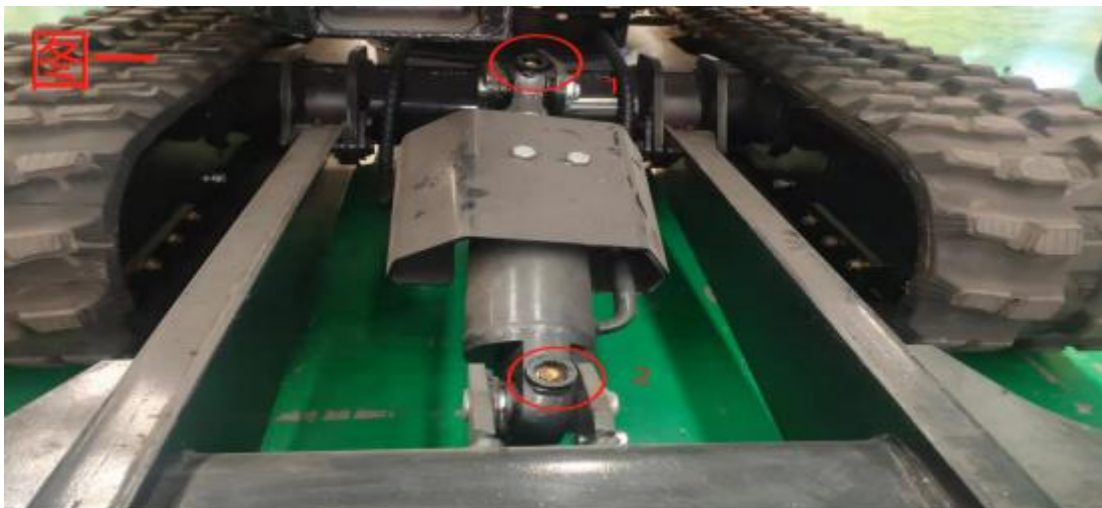

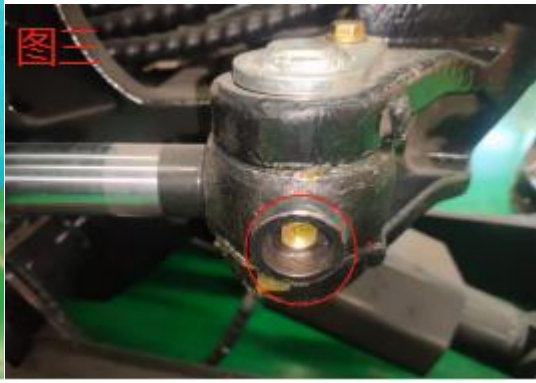



Users must add enough butter to the above refueling points every 8 hours.

### 10.3 Maintenance catalog

Excavator maintenance catalog

Filter element name	First time		conventional		model	Remark
	time	Maintenance method	time	Maintenance method		
Oil filter	50h	replace	200h	replace	/	
Air filter	50h	Clean up	200h	replace	/	For severe working conditions, the cleaning and replacement cycle will be shortened (air blowing, not washing)
Diesel filter	50h	replace	200h	replace	/	
Pilot filter	500h	replace	1000h	replace	/	
Hydraulic suction filter	300h	replace	600h	replace	/	
Hydraulic oil return filter	300h	replace	300h	replace	/	

+ |

Oil name	First time		conventional		model	Remark
	time	Maintenance method	time	Maintenance method		
Engine oil	50h	replace	200H	replace	CD 15W-40 (PC10 model) CF-4 15W-40 (other model)	Use the appropriate oil model according to the local temperature
antifreeze	every day	Check/Supplement	One year	replace	No. 40 glycol type engine coolant	Can not be mixed with water, can not be replaced with water (use the appropriate antifreeze model according to the local temperature)
diesel fuel	every day	Check/Supplement	/	/	/	Use diesel from regular gas stations. Inferior diesel will cause damage to fuel pumps, fuel injectors and other components (use appropriate diesel grades according to local temperature)
Hydraulic oil	300h	replace	600h	replace	46#Anti-wear hydraulic oil	
Travel motor gear oil	50h	replace	500h	replace	L-CKD 220	
butter	New machines	Raise	8h	add	/	
Water tank radiator	50h	Clean up	50h	Clean up	/	Air blowing or high-pressure water flushing

Hydraulic oil radiator	50h	Clean up	50h	Clean up	/	Air blowing or high-pressure water flushing
------------------------	-----	----------	-----	----------	---	---

Important inspection site	time	Maintenance method	time	Maintenance method	Remark
Rotary motor fixed screw	30H	check	30H	check	If it is loose, please tighten it immediately
Slewing support fixed screw	30H	check	30H	check	If it is loose, please tighten it immediately
Engine fixed screw	30H	check	30H	check	If it is loose, please tighten it immediately
Track tensioner	Before work	check	Before work	check	If the track becomes loose, please add butter immediately

Notice: 1. Please follow the maintenance cycle, regular maintenance, the manufacturer does not provide three guarantees for equipment failures caused by untimely maintenance or non-maintenance

2. Please use genuine parts for maintenance. Inferior parts or oil may cause rapid wear or serious failure of the equipment

3. Failure to check the slewing motor fixing screws, slewing support fixing screws, and engine fixing screws regularly may result in slewing motor gear toothing, flange damage, slewing support toothing, engine wind ring damage, water tank leakage and other accidents. The manufacturer does not provide three guarantees for damaged parts.

## 10.4 List of filter element models

	L330 model	
Air filter / model		
Chai filter / model		CX0708

Machine filter / model	 <p>JX0810Y</p>
Oil absorption filter element / model	
Return oil filter element / model	
Pilot filter element / model	 <p>YL-132</p>

## 10.5 Change the oil

### L330 Model type oil replacement method

As shown in the figure below, open the rear protective cover of the excavator, remove the oil release outlet screw with a wrench, and then tighten the screw after the engine oil is put in. Then remove the refueling port screw, remove the cover

plate of the refueling port, extend your hand to the refueling port, unscrew the oil cover, add new oil to the engine, observe the oil ruler level while adding, the oil filling amount is close to the upper limit of the oil ruler but not exceeding the upper limit, tighten the oil cover after adding oil.



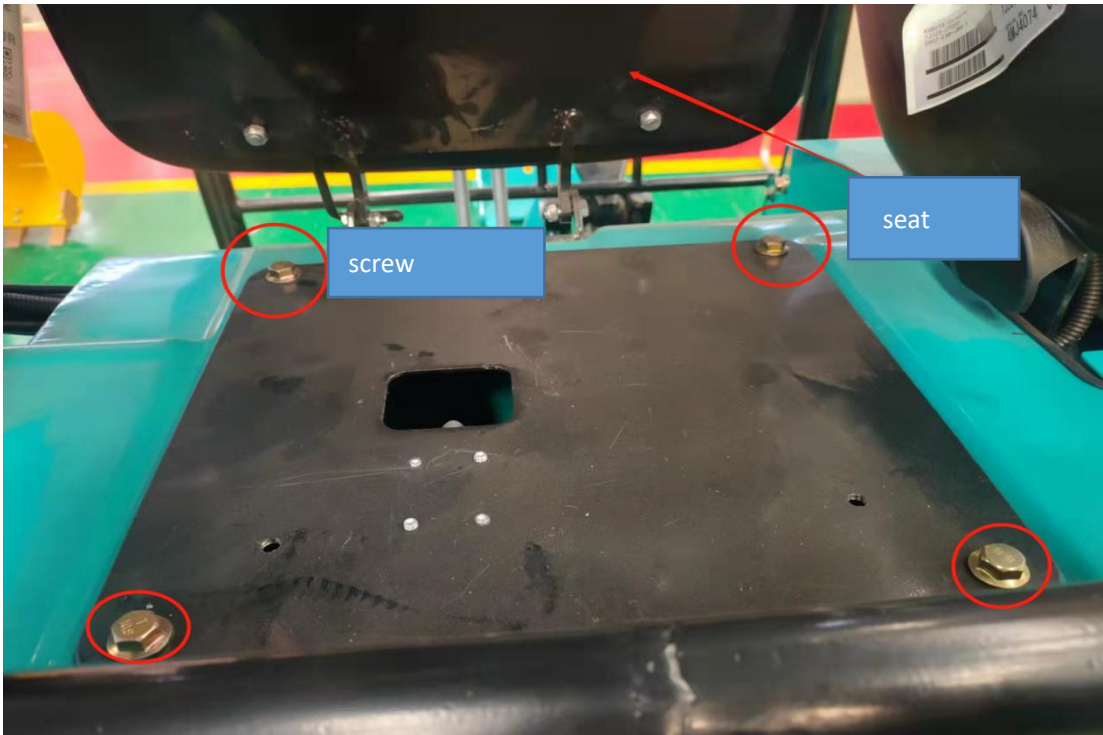
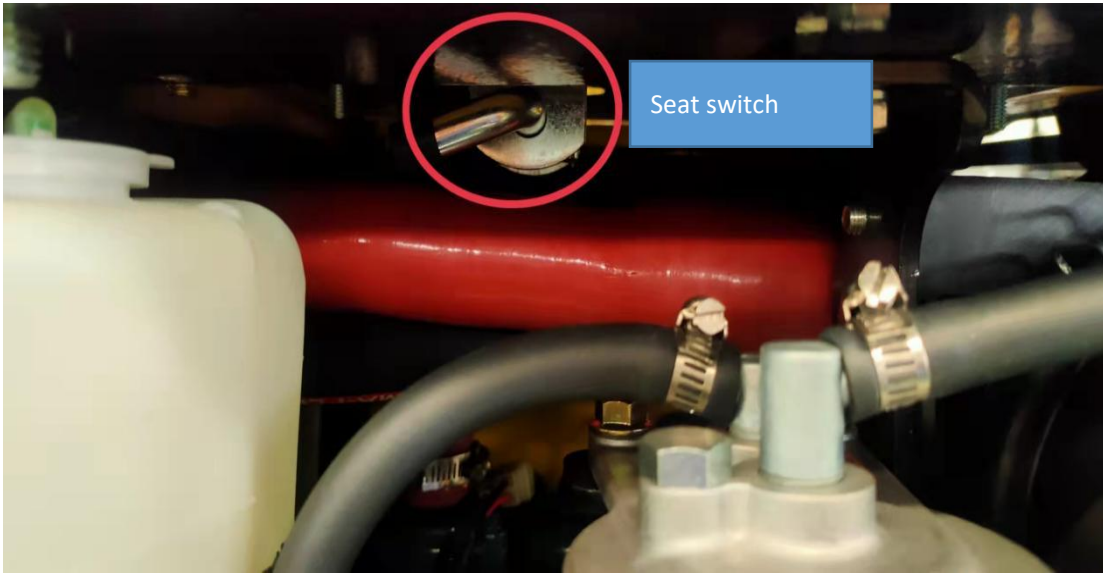

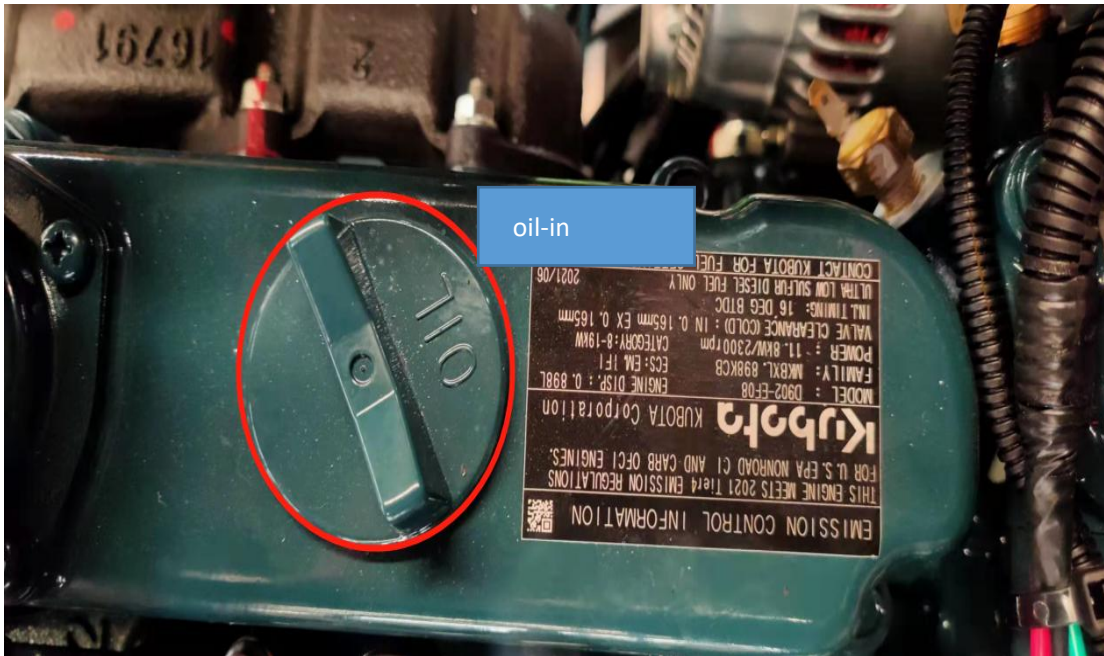

## 10.6 Filter replacement method

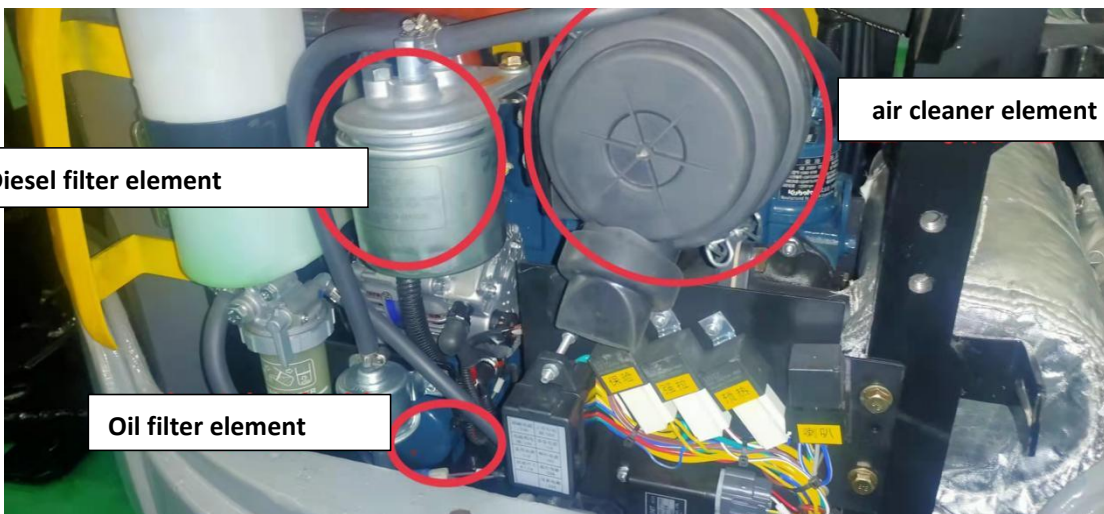



## How to change the filter element:

Method of changing filter element:

As shown in the figure above, if the air filter element, diesel filter element and oil filter element of the L330 model are replaced, you need to open the rear excavator cover first, and all the filter elements can be seen after opening. Remove the oil pipe and joint on the filter element with a wrench first, and then remove the filter element for replacement. The air filter is replaced by removing the housing, and the diesel filter and oil filter are replaced

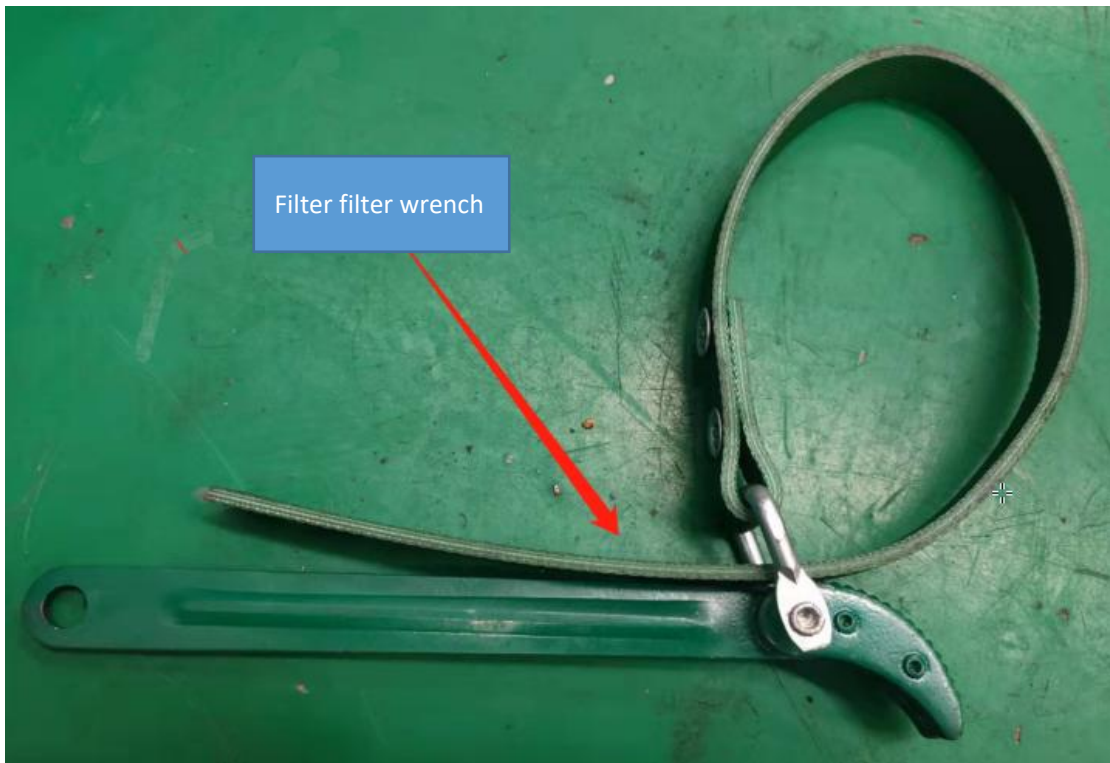

with the whip in the tool.

# List of accessories and spare parts

## 一、List of accessories and spare parts

1、foot pad

## 二、Vehicle accessories

Accessory name	quantity	model
		L330
Screwdriver (one word)	1pc	○
screwdriver (cross)	1pc	○
M12/14/16 socket	1 each	○
M27 socket	1pc	/
Sleeve corner	1pc	○
grease gun	1pc	/
Adjustable wrench	1pc	○
toolbox	1pc	○
filter wrench	1pc	○
Allen key	1set	○
Hydraulic oil (oil return) filter element	1pc	○

## 三、Random document

1. 1 operation and maintenance manual
2. Three Guarantees Service Certificate 1
3. 1 certificate of qualification
4. 1 engine instruction manual
5. 1 certificate of engine three guarantees
6. List of market service network 1 copy